Arithmetic for Computers

Abstract

This chapter describes how computers handle arithmetic data. It explains that computer words (which are composed of bits) can be represented as binary numbers. While integers can be easily converted to decimal or binary form, fractions and other real numbers can also be converted, as this chapter shows. This chapter also explains what happens if an operation creates a number bigger than can be represented, and answers the question of how the computer hardware multiplies and divides numbers.

Keywords

Computer arithmetic; addition; subtraction; multiplication; division; associativity; x86; Arithmetic Logic Unit; ALU; exception; interrupt; dividend; divisor; quotient; remainder; scientific notation; normalized; floating point; fraction; exponent; overflow; underflow; double precision; single precision; guard; round; units in the last place; ULP; sticky bit; fused multiply add; matrix multiply; SIMD; subword parallelism

Numerical precision is the very soul of science.

Sir D'arcy Wentworth Thompson, On Growth and Form, 1917

OUTLINE

[3.1 Introduction](#) 174

3.2 Addition and Subtraction	174
3.3 Multiplication	177
3.4 Division	183
3.5 Floating Point	191
3.6 Parallelism and Computer Arithmetic: Subword Parallelism	216
3.7 Real Stuff: Streaming SIMD Extensions and Advanced Vector Extensions in x86	217
3.8 Going Faster: Subword Parallelism and Matrix Multiply	218
3.9 Fallacies and Pitfalls	222
3.10 Concluding Remarks	225
 3.11 Historical Perspective and Further Reading	227
3.12 Exercises	227

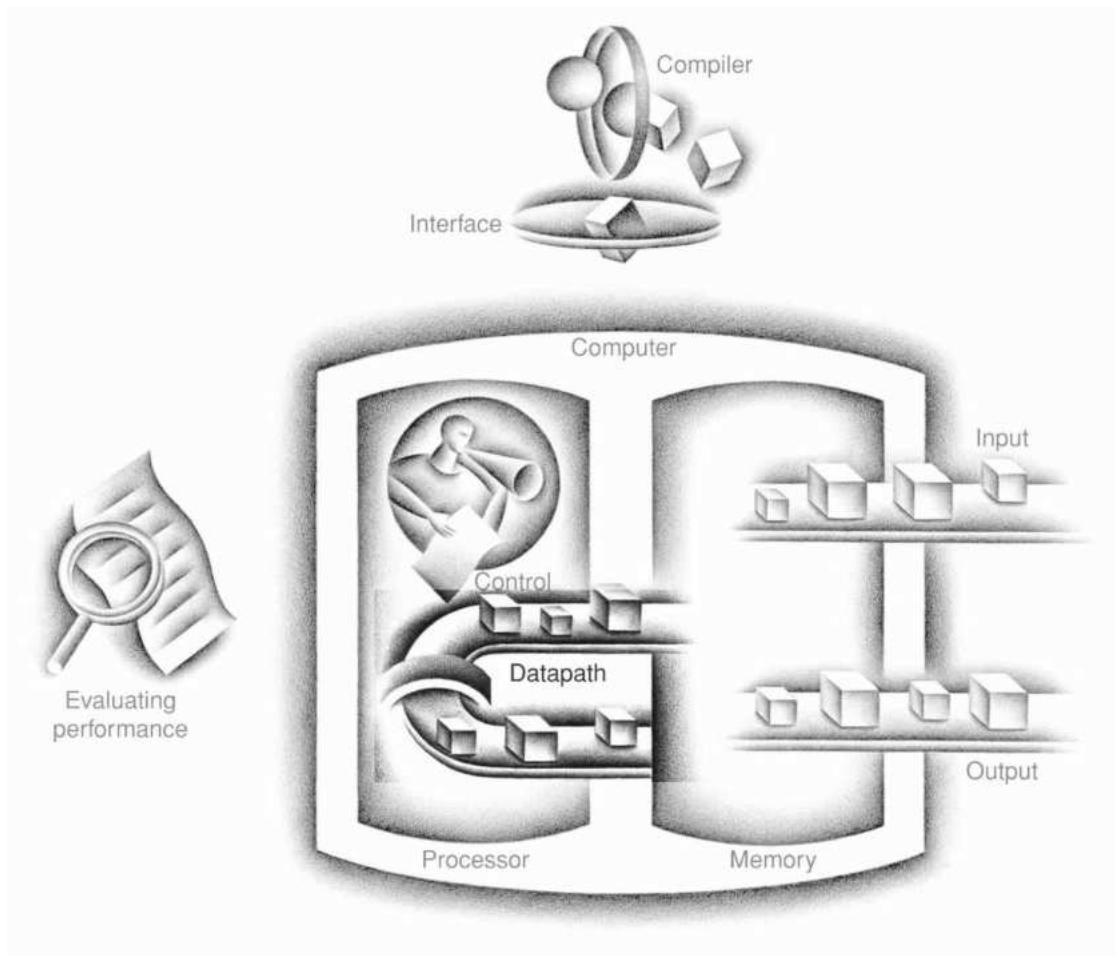

The Five Classic Components of a Computer

3.1 Introduction

Computer words are composed of bits; thus, words can be represented as binary numbers. [Chapter 2](#) shows that integers can be represented either in decimal or binary form, but what about the other numbers that commonly occur? For example:

- What about fractions and other real numbers?
- What happens if an operation creates a number bigger than can be represented?
- And underlying these questions is a mystery: How does hardware really multiply or divide numbers?

The goal of this chapter is to unravel these mysteries—including representation of real numbers, arithmetic algorithms, hardware that follows these algorithms—and the implications of all this for instruction sets. These insights may explain quirks that you have

already encountered with computers. Moreover, we show how to use this knowledge to make arithmetic-intensive programs go much faster.

3.2 Addition and Subtraction

Addition is just what you would expect in computers. Digits are added bit by bit from right to left, with carries passed to the next digit to the left, just as you would do by hand. Subtraction uses addition: the appropriate operand is simply negated before being added.

Subtraction: Addition's Tricky Pal

No. 10, Top Ten Courses for Athletes at a Football Factory, David Letterman et al., Book of Top Ten Lists, 1990

Binary Addition and Subtraction

Example

Let's try adding 6_{ten} to 7_{ten} in binary and then subtracting 6_{ten} from 7_{ten} in binary.

```

00000000 00000000 00000000 00000000 00000000 00000000 00000000 00000111two = 7ten
+ 00000000 00000000 00000000 00000000 00000000 00000000 00000000 00000110two = 6ten
-----
= 00000000 00000000 00000000 00000000 00000000 00000000 00000000 00001101two = 13ten

```

The 4 bits to the right have all the action; [Figure 3.1](#) shows the sums and carries. Parentheses identify the carries, with the arrows illustrating how they are passed.

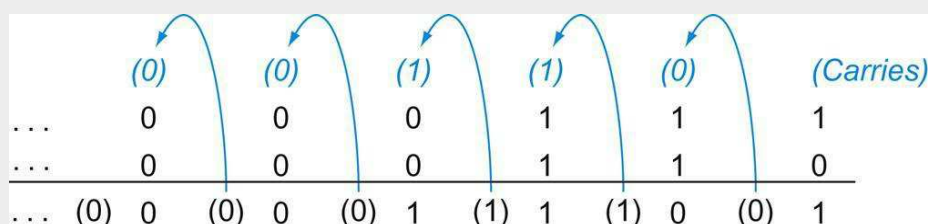

FIGURE 3.1 Binary addition, showing carries from

right to left.

The rightmost bit adds 1 to 0, resulting in the sum of this bit being 1 and the carry out from this bit being 0. Hence, the operation for the second digit to the right is $0 + 1 + 1$. This generates a 0 for this sum bit and a carry out of 1. The third digit is the sum of $1 + 1 + 1$, resulting in a carry out of 1 and a sum bit of 1. The fourth bit is $1 + 0 + 0$, yielding a 1 sum and no carry.

Answer

Subtracting 6_{ten} from 7_{ten} can be done directly:

$$\begin{array}{r} 00000000\ 00000000\ 00000000\ 00000000\ 00000000\ 00000000\ 00000000\ 00000111\ =\ 7_{\text{two}} \\ -\ 00000000\ 00000000\ 00000000\ 00000000\ 00000000\ 00000000\ 00000000\ 00000110\ =\ 6_{\text{two}} \\ \hline =\ 00000000\ 00000000\ 00000000\ 00000000\ 00000000\ 00000000\ 00000000\ 00000001\ =\ 1_{\text{two}} \end{array}$$

or via addition using the two's complement representation of -6 :

$$\begin{array}{r} 00000000\ 00000000\ 00000000\ 00000000\ 00000000\ 00000000\ 00000000\ 00000111\ =\ 7_{\text{two}} \\ +\ 11111111\ 11111111\ 11111111\ 11111111\ 11111111\ 11111111\ 11111111\ 11111010\ =\ -6_{\text{two}} \\ \hline =\ 00000000\ 00000000\ 00000000\ 00000000\ 00000000\ 00000000\ 00000000\ 00000001\ =\ 1_{\text{two}} \end{array}$$

Recall that overflow occurs when the result from an operation cannot be represented with the available hardware, in this case a 64-bit word. When can overflow occur in addition? When adding operands with different signs, overflow cannot occur. The reason is the sum must be no larger than one of the operands. For example, $-10 + 4 = -6$. Since the operands fit in 64 bits and the sum is no larger than an operand, the sum must fit in 64 bits as well. Therefore, no overflow can occur when adding positive and negative operands.

There are similar restrictions to the occurrence of overflow during subtract, but it's just the opposite principle: when the signs of the operands are the *same*, overflow cannot occur. To see this, remember that $c - a = c + (-a)$ because we subtract by negating the second operand and then add. Therefore, when we subtract operands of the same sign we end up *adding* operands of *different* signs. From the prior paragraph, we know that overflow cannot

occur in this case either.

Knowing when an overflow cannot occur in addition and subtraction is all well and good, but how do we detect it when it *does* occur? Clearly, adding or subtracting two 64-bit numbers can yield a result that needs 65 bits to be fully expressed.

The lack of a 65th bit means that when an overflow occurs, the sign bit is set with the *value* of the result instead of the proper sign of the result. Since we need just one extra bit, only the sign bit can be wrong. Hence, overflow occurs when adding two positive numbers and the sum is negative, or vice versa. This spurious sum means a carry out occurred into the sign bit.

Overflow occurs in subtraction when we subtract a negative number from a positive number and get a negative result, or when we subtract a positive number from a negative number and get a positive result. Such a ridiculous result means a borrow occurred from the sign bit. [Figure 3.2](#) shows the combination of operations, operands, and results that indicate an overflow.

Operation	Operand A	Operand B	Result indicating overflow
$A + B$	≥ 0	≥ 0	< 0
$A + B$	< 0	< 0	≥ 0
$A - B$	≥ 0	< 0	< 0
$A - B$	< 0	≥ 0	≥ 0

FIGURE 3.2 Overflow conditions for addition and subtraction.

We have just seen how to detect overflow for two's complement numbers in a computer. What about overflow with unsigned integers? Unsigned integers are commonly used for memory addresses where overflows are ignored.

Fortunately, the compiler can easily check for unsigned overflow using a branch instruction. Addition has overflowed if the sum is less than either of the addends, whereas subtraction has overflowed if the difference is greater than the minuend.

[Appendix A](#) describes the hardware that performs addition and subtraction, which is called an **Arithmetic Logic Unit** or **ALU**.

Arithmetic Logic Unit (ALU)

Hardware that performs addition, subtraction, and usually logical operations such as AND and OR.

Hardware/Software Interface

The computer designer must decide how to handle arithmetic overflows. Although some languages like C and Java ignore integer overflow, languages like Ada and Fortran require that the program be notified. The programmer or the programming environment must then decide what to do when an overflow occurs.

Summary

A major point of this section is that, independent of the representation, the finite word size of computers means that arithmetic operations can create results that are too large to fit in this fixed word size. It's easy to detect overflow in unsigned numbers, although these are almost always ignored because programs don't want to detect overflow for address arithmetic, the most common use of natural numbers. Two's complement presents a greater challenge, yet some software systems require recognizing overflow, so today all computers have a way to detect it.

Check Yourself

Some programming languages allow two's complement integer arithmetic on variables declared byte and half, whereas RISC-V only has integer arithmetic operations on full words. As we recall from [Chapter 2](#), RISC-V does have data transfer operations for bytes and halfwords. What RISC-V instructions should be generated for byte and halfword arithmetic operations?

1. Load with `lb`, `lh`; arithmetic with `add`, `sub`, `mul`, `div`, using `and` to mask result to 8 or 16 bits after each operation; then store using `sb`, `sh`.
2. Load with `lb`, `lh`; arithmetic with `add`, `sub`, `mul`, `div`; then store using `sb`, `sh`.

Elaboration

One feature not generally found in general-purpose microprocessors is saturating operations. *Saturation* means that when a calculation overflows, the result is set to the largest positive number or the most negative number, rather than a modulo calculation as in two's complement arithmetic. Saturation is likely what you want for media operations. For example, the volume knob on a radio set would be frustrating if, as you turned it, the volume would get continuously louder for a while and then immediately very soft. A knob with saturation would stop at the highest volume no matter how far you turned it. Multimedia extensions to standard instruction sets often offer saturating arithmetic.

Elaboration

The speed of addition depends on how quickly the carry into the high-order bits is computed. There are a variety of schemes to anticipate the carry so that the worst-case scenario is a function of the \log_2 of the number of bits in the adder. These anticipatory signals are faster because they go through fewer gates in sequence, but it takes many more gates to anticipate the proper carry. The most popular is *carry lookahead*, which [Section A.6 in Appendix A](#) describes.

3.3 Multiplication

Now that we have completed the explanation of addition and subtraction, we are ready to build the more vexing operation of multiplication.

*Multiplication is vexation, Division is as bad;
The rule of three doth puzzle me,
And practice drives me mad.*

Anonymous, Elizabethan manuscript, 1570

First, let's review the multiplication of decimal numbers in longhand to remind ourselves of the steps of multiplication and the names of the operands. For reasons that will become clear shortly,

we limit this decimal example to using only the digits 0 and 1.
 Multiplying 1000_{ten} by 1001_{ten} :

Multiplicand		1000
Multiplier	×	1001 _{ten}
		<hr style="width: 100%; border: 0.5px solid black;"/>
		1000
		0000
		0000
		1000
		<hr style="width: 100%; border: 0.5px solid black;"/>
Product		1001000 _{ten}

The first operand is called the *multiplicand* and the second the *multiplier*. The final result is called the *product*. As you may recall, the algorithm learned in grammar school is to take the digits of the multiplier one at a time from right to left, multiplying the multiplicand by the single digit of the multiplier, and shifting the intermediate product one digit to the left of the earlier intermediate products.

The first observation is that the number of digits in the product is considerably larger than the number in either the multiplicand or the multiplier. In fact, if we ignore the sign bits, the length of the multiplication of an n -bit multiplicand and an m -bit multiplier is a product that is $n+m$ bits long. That is, $n+m$ bits are required to represent all possible products. Hence, like add, multiply must cope with overflow because we frequently want a 64-bit product as the result of multiplying two 64-bit numbers.

In this example, we restricted the decimal digits to 0 and 1. With only two choices, each step of the multiplication is simple:
 1. Just place a copy of the multiplicand ($1 \times$ multiplicand) in the proper place if the multiplier digit is a 1, or

2. Place 0 ($0 \times$ multiplicand) in the proper place if the digit is 0.

Although the decimal example above happens to use only 0 and 1, multiplication of binary numbers must always use 0 and 1, and thus always offers only these two choices.

Now that we have reviewed the basics of multiplication, the traditional next step is to provide the highly optimized multiply hardware. We break with tradition in the belief that you will gain a better understanding by seeing the evolution of the multiply hardware and algorithm through multiple generations. For now, let's assume that we are multiplying only positive numbers.

Sequential Version of the Multiplication Algorithm and Hardware

This design mimics the algorithm we learned in grammar school; [Figure 3.3](#) shows the hardware. We have drawn the hardware so that data flow from top to bottom to resemble more closely the paper-and-pencil method.

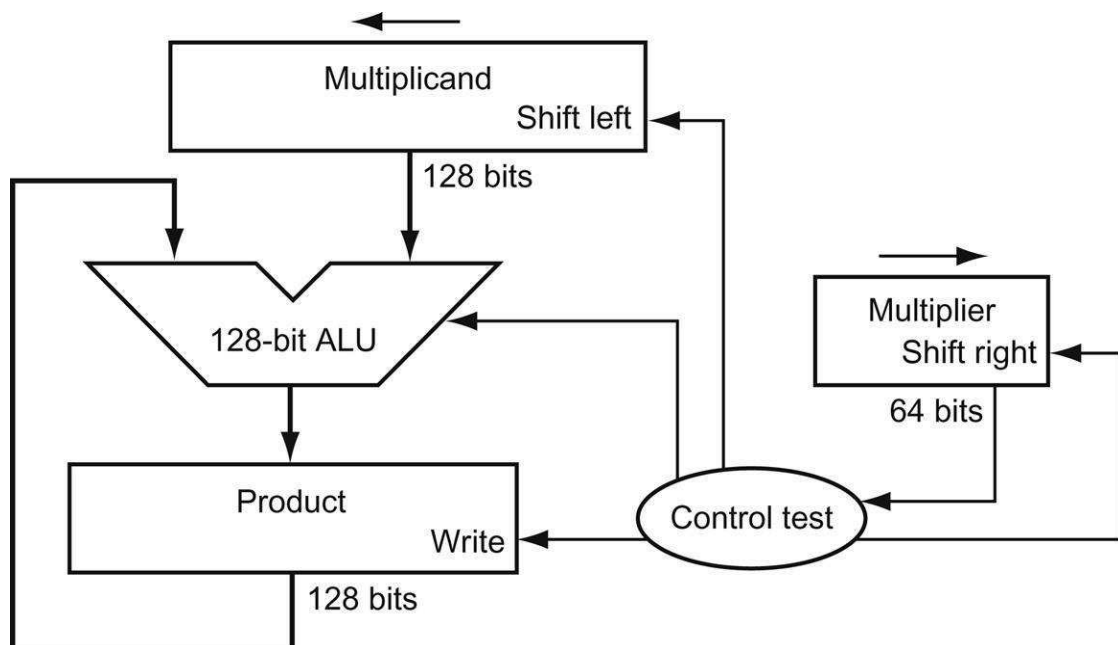

FIGURE 3.3 First version of the multiplication hardware.

The Multiplicand register, ALU, and Product register are all 128 bits wide, with only the Multiplier register containing 64 bits. ([Appendix A](#) describes ALUs.) The 64-bit multiplicand starts in the right half of the

Multiplicand register and is shifted left 1 bit on each step. The multiplier is shifted in the opposite direction at each step. The algorithm starts with the product initialized to 0. Control decides when to shift the Multiplicand and Multiplier registers and when to write new values into the Product register.

Let's assume that the multiplier is in the 64-bit Multiplier register and that the 128-bit Product register is initialized to 0. From the paper-and-pencil example above, it's clear that we will need to move the multiplicand left one digit each step, as it may be added to the intermediate products. Over 64 steps, a 64-bit multiplicand would move 64 bits to the left. Hence, we need a 128-bit Multiplicand register, initialized with the 64-bit multiplicand in the right half and zero in the left half. This register is then shifted left 1 bit each step to align the multiplicand with the sum being accumulated in the 128-bit Product register.

[Figure 3.4](#) shows the three basic steps needed for each bit. The least significant bit of the multiplier (Multiplier0) determines whether the multiplicand is added to the Product register. The left shift in step 2 has the effect of moving the intermediate operands to the left, just as when multiplying with paper and pencil. The shift right in step 3 gives us the next bit of the multiplier to examine in the following iteration. These three steps are repeated 64 times to obtain the product. If each step took a clock cycle, this algorithm would require almost 200 clock cycles to multiply two 64-bit numbers. The relative importance of arithmetic operations like multiply varies with the program, but addition and subtraction may be anywhere from 5 to 100 times more popular than multiply. Accordingly, in many applications, multiply can take several clock cycles without significantly affecting performance. However, Amdahl's Law (see [Section 1.10](#)) reminds us that even a moderate frequency for a slow operation can limit performance.

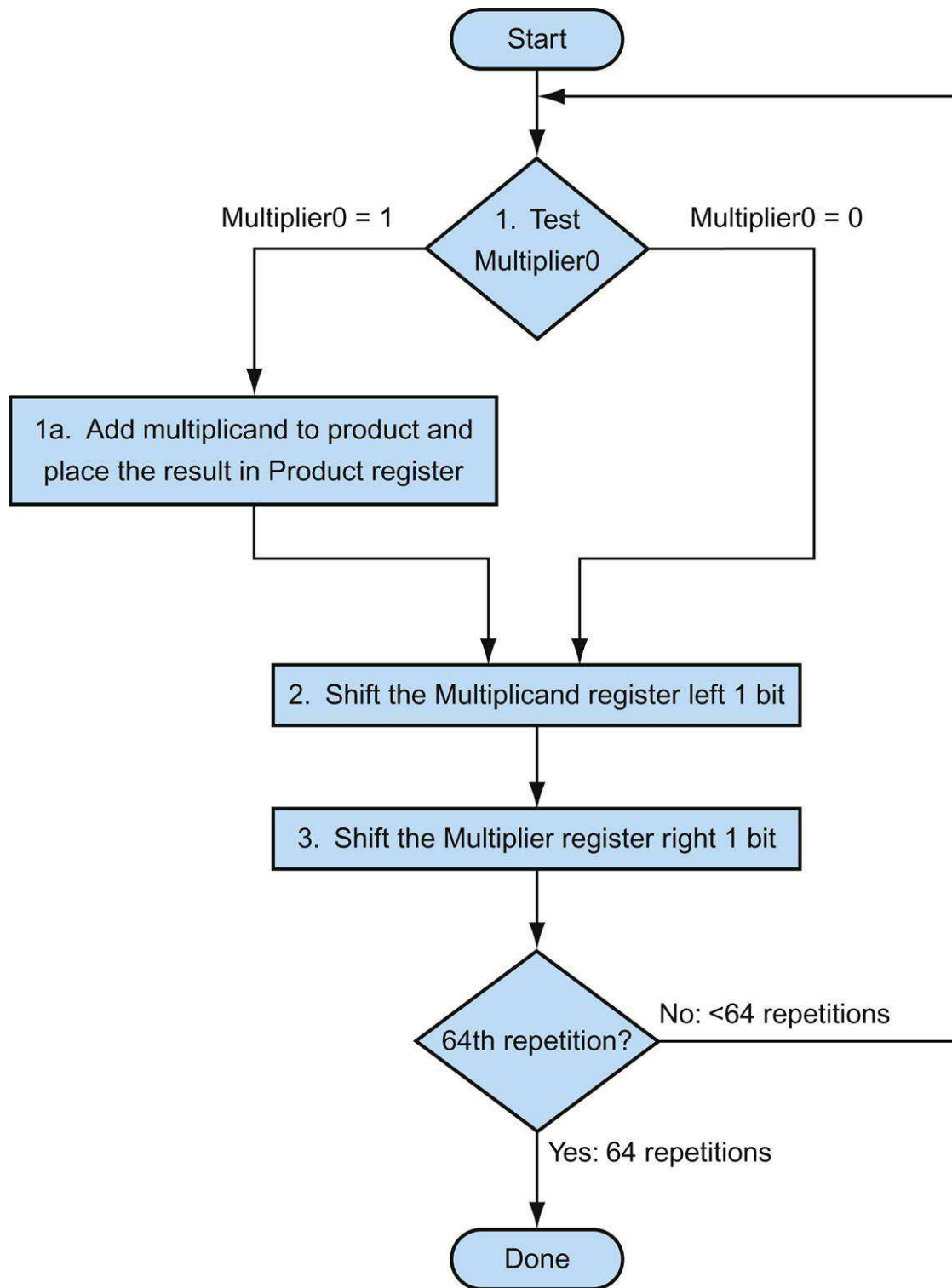

FIGURE 3.4 The first multiplication algorithm, using the hardware shown in [Figure 3.3](#). If the least significant bit of the multiplier is 1, add the multiplicand to the product. If not, go to the next step. Shift the multiplicand left and the multiplier right in the next two steps. These three steps are repeated 64 times.

This algorithm and hardware are easily refined to take one clock cycle per step. The speed up comes from performing the operations in parallel: the multiplier and multiplicand are shifted while the multiplicand is added to the product if the multiplier bit is a 1. The hardware just has to ensure that it tests the right bit of the multiplier and gets the preshifted version of the multiplicand. The hardware is usually further optimized to halve the width of the adder and registers by noticing where there are unused portions of registers and adders. [Figure 3.5](#) shows the revised hardware.

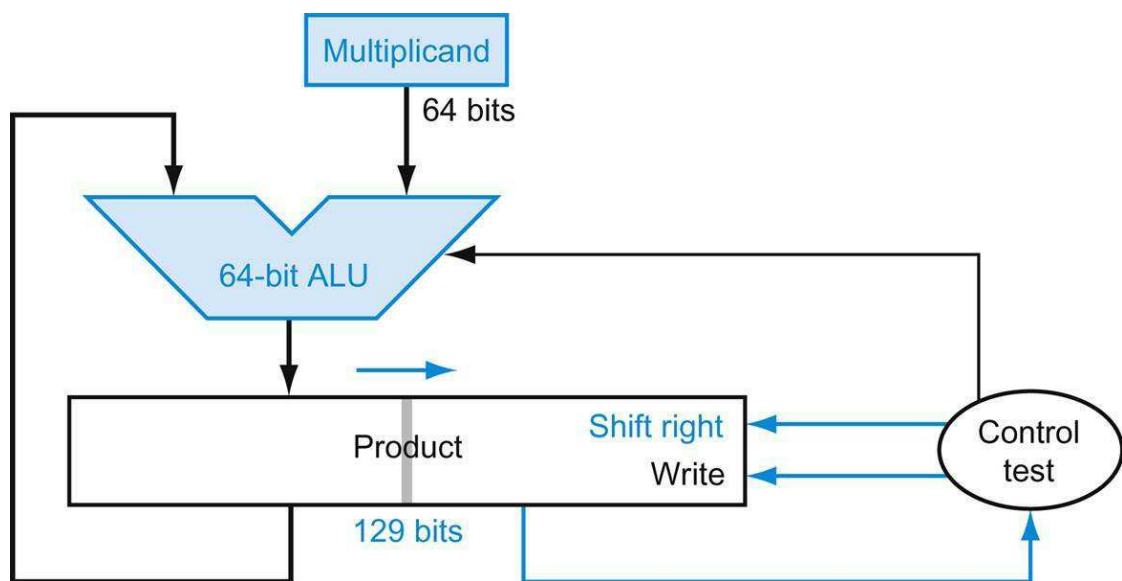

FIGURE 3.5 Refined version of the multiplication hardware.

Compare with the first version in [Figure 3.3](#). The Multiplicand register and ALU have been reduced to 64 bits. Now the product is shifted right. The separate Multiplier register also disappeared. The multiplier is placed instead in the right half of the Product register, which has grown by one bit to 129 bits to hold the carry-out of the adder. These changes are highlighted in color.

Hardware/Software Interface

Replacing arithmetic by shifts can also occur when multiplying by constants. Some compilers replace multiplies by short constants with a series of shifts and adds. Because one bit to the left represents a number twice as large in base 2, shifting the bits left

has the same effect as multiplying by a power of 2. As mentioned in [Chapter 2](#), almost every compiler will perform the strength reduction optimization of substituting a left shift for a multiply by a power of 2.

A Multiply Algorithm

Example

Using 4-bit numbers to save space, multiply $2_{\text{ten}} \times 3_{\text{ten}}$, or $0010_{\text{two}} \times 0011_{\text{two}}$.

Answer

[Figure 3.6](#) shows the value of each register for each of the steps labeled according to [Figure 3.4](#), with the final value of $0000\ 0110_{\text{two}}$ or 6_{ten} . Color is used to indicate the register values that change on that step, and the bit circled is the one examined to determine the operation of the next step.

Iteration	Step	Multiplier	Multiplicand	Product
0	Initial values	001 ^①	0000 0010	0000 0000
1	1a: $1 \Rightarrow \text{Prod} = \text{Prod} + \text{Mcand}$	0011	0000 0010	0000 0010
	2: Shift left Multiplicand	0011	0000 0100	0000 0010
	3: Shift right Multiplier	000 ^①	0000 0100	0000 0010
2	1a: $1 \Rightarrow \text{Prod} = \text{Prod} + \text{Mcand}$	0001	0000 0100	0000 0110
	2: Shift left Multiplicand	0001	0000 1000	0000 0110
	3: Shift right Multiplier	000 ^①	0000 1000	0000 0110
3	1: $0 \Rightarrow$ No operation	0000	0000 1000	0000 0110
	2: Shift left Multiplicand	0000	0001 0000	0000 0110
	3: Shift right Multiplier	000 ^①	0001 0000	0000 0110
4	1: $0 \Rightarrow$ No operation	0000	0001 0000	0000 0110
	2: Shift left Multiplicand	0000	0010 0000	0000 0110
	3: Shift right Multiplier	0000	0010 0000	0000 0110

FIGURE 3.6 Multiply example using algorithm in [Figure 3.4](#).

The bit examined to determine the next step is circled in color.

Signed Multiplication

So far, we have dealt with positive numbers. The easiest way to

understand how to deal with signed numbers is to first convert the multiplier and multiplicand to positive numbers and then remember their original signs. The algorithms should next be run for 31 iterations, leaving the signs out of the calculation. As we learned in grammar school, we need negate the product only if the original signs disagree.

It turns out that the last algorithm will work for signed numbers, if we remember that we are dealing with numbers that have infinite digits, and we are only representing them with 64 bits. Hence, the shifting steps would need to extend the sign of the product for signed numbers. When the algorithm completes, the lower doubleword would have the 64-bit product.

Faster Multiplication

Moore's Law has provided so much more in resources that hardware designers can now build much faster multiplication hardware. Whether the multiplicand is to be added or not is known at the beginning of the multiplication by looking at each of the 64 multiplier bits. Faster multiplications are possible by essentially providing one 64-bit adder for each bit of the multiplier: one input is the multiplicand ANDed with a multiplier bit, and the other is the output of a prior adder.

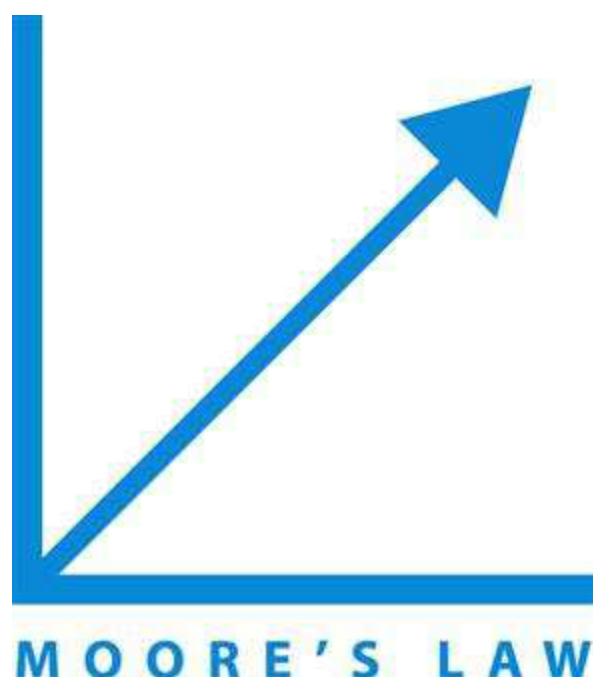

A straightforward approach would be to connect the outputs of adders on the right to the inputs of adders on the left, making a stack of adders 64 high. An alternative way to organize these 64 additions is in a parallel tree, as [Figure 3.7](#) shows. Instead of waiting for 64 add times, we wait just the $\log_2(64)$ or six 64-bit add times.

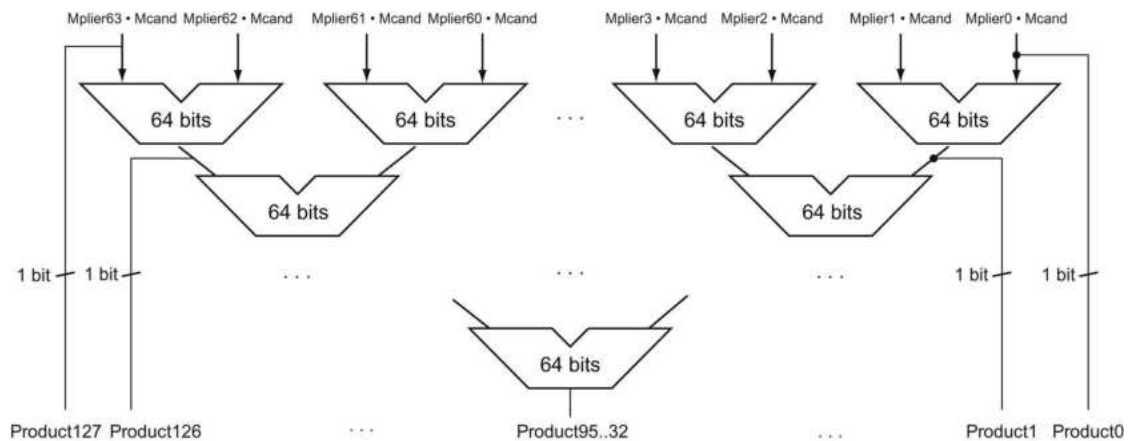
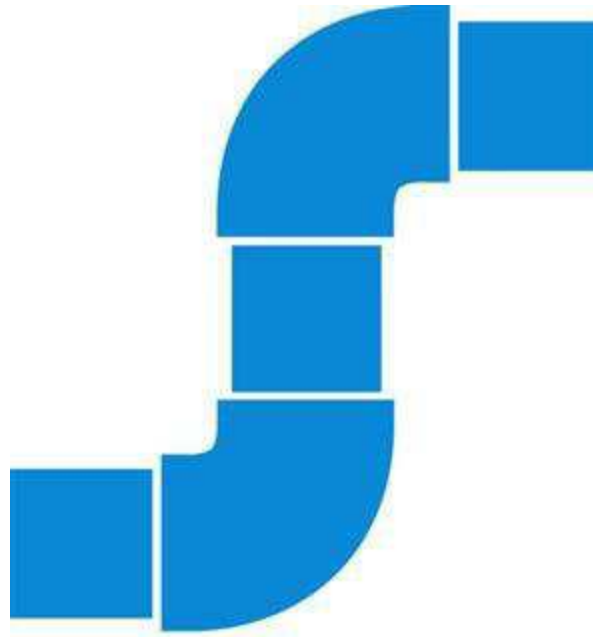

FIGURE 3.7 Fast multiplication hardware.

Rather than use a single 64-bit adder 63 times, this hardware “unrolls the loop” to use 63 adders and then organizes them to minimize delay.

In fact, multiply can go even faster than six add times because of the use of *carry save adders* (see [Section A.6 in Appendix A](#)), and because it is easy to **pipeline** such a design to be able to support many multiplies simultaneously (see [Chapter 4](#)).



PIPELINING

Multiply in RISC-V

To produce a properly signed or unsigned 128-bit product, RISC-V has four instructions: *multiply* (`mul`), *multiply high* (`mulh`), *multiply high unsigned* (`mulhu`), and *multiply high signed-unsigned* (`mulhsu`). To get the integer 64-bit product, the programmer uses `mul`. To get the upper 64 bits of the 128-bit product, the programmer uses (`mulh`) if both operands are signed, (`mulhu`) if both operands are unsigned, or (`mulhsu`) if one operand is signed and the other is unsigned.

Summary

Multiplication hardware simply shifts and adds, as derived from the paper-and-pencil method learned in grammar school. Compilers even use shift instructions for multiplications by powers of 2. With much more hardware we can do the adds in **parallel**, and do them much faster.



PARALLELISM

Hardware/Software Interface

Software can use the multiply-high instructions to check for overflow from 64-bit multiplication. There is no overflow for 64-bit unsigned multiplication if `mulhu`'s result is zero. There is no overflow for 64-bit signed multiplication if all of the bits in `mulh`'s result are copies of the sign bit of `mul`'s result.

3.4 Division

The reciprocal operation of multiply is divide, an operation that is even less frequent and even quirkier. It even offers the opportunity to perform a mathematically invalid operation: dividing by 0.

Divide et impera.

Latin for "Divide and rule," ancient political maxim cited by Machiavelli, 1532

Let's start with an example of long division using decimal numbers to recall the names of the operands and the division algorithm from grammar school. For reasons similar to those in the previous section, we limit the decimal digits to just 0 or 1. The example is dividing $1,001,010_{\text{ten}}$ by 1000_{ten} :

	1001_{ten}	Quotient
Divisor 1000_{ten}	1001010_{ten}	Dividend
	-1000	
	10	
	101	
	1010	
	-1000	
	10_{ten}	Remainder

Divide's two operands, called the **dividend** and **divisor**, and the result, called the **quotient**, are accompanied by a second result, called the **remainder**. Here is another way to express the relationship between the components:

dividend

A number being divided.

divisor

A number that the dividend is divided by.

quotient

The primary result of a division; a number that when multiplied by the divisor and added to the remainder produces the dividend.

remainder

The secondary result of a division; a number that when added to the product of the quotient and the divisor produces the dividend.

$$\text{Dividend} = \text{Quotient} \times \text{Divisor} + \text{Remainder}$$

where the remainder is smaller than the divisor. Infrequently, programs use the divide instruction just to get the remainder,

ignoring the quotient.

The basic division algorithm from grammar school tries to see how big a number can be subtracted, creating a digit of the quotient on each attempt. Our carefully selected decimal example uses just the numbers 0 and 1, so it's easy to figure out how many times the divisor goes into the portion of the dividend: it's either 0 times or 1 time. Binary numbers contain only 0 or 1, so binary division is restricted to these two choices, thereby simplifying binary division.

Let's assume that both the dividend and the divisor are positive and hence the quotient and the remainder are nonnegative. The division operands and both results are 64-bit values, and we will ignore the sign for now.

A Division Algorithm and Hardware

Figure 3.8 shows hardware to mimic our grammar school algorithm. We start with the 64-bit Quotient register set to 0. Each iteration of the algorithm needs to move the divisor to the right one digit, so we start with the divisor placed in the left half of the 128-bit Divisor register and shift it right 1 bit each step to align it with the dividend. The Remainder register is initialized with the dividend.

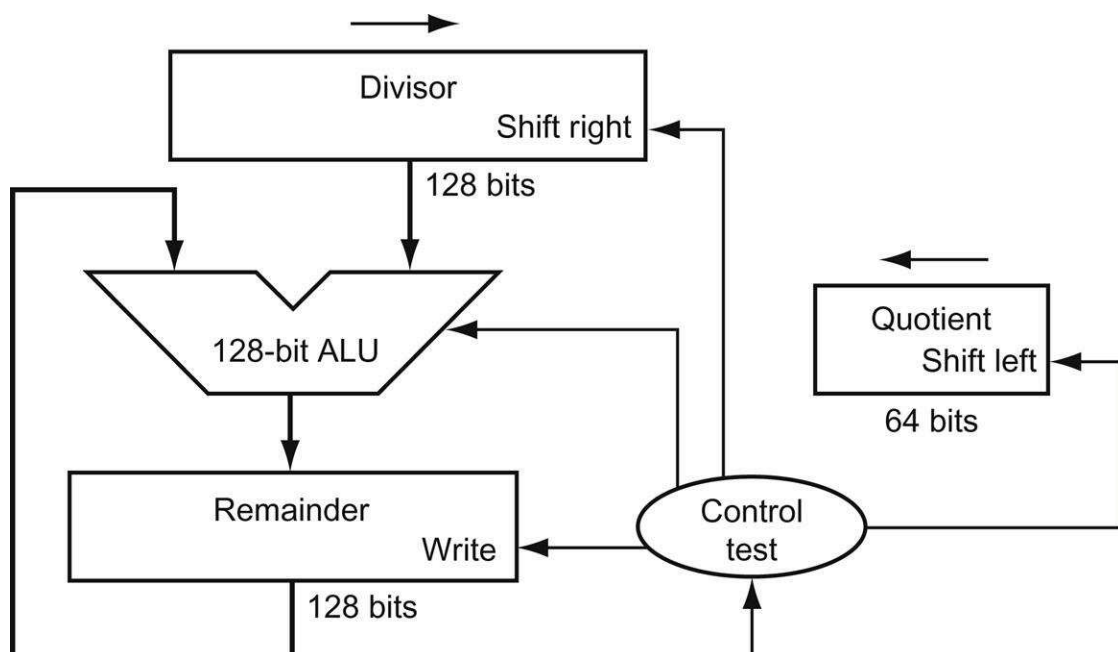

FIGURE 3.8 First version of the division hardware. The Divisor register, ALU, and Remainder register are

all 128 bits wide, with only the Quotient register being 62 bits. The 64-bit divisor starts in the left half of the Divisor register and is shifted right 1 bit each iteration. The remainder is initialized with the dividend. Control decides when to shift the Divisor and Quotient registers and when to write the new value into the Remainder register.

Figure 3.9 shows three steps of the first division algorithm. Unlike a human, the computer isn't smart enough to know in advance whether the divisor is smaller than the dividend. It must first subtract the divisor in step 1; remember that this is how we performed comparison. If the result is positive, the divisor was smaller or equal to the dividend, so we generate a 1 in the quotient (step 2a). If the result is negative, the next step is to restore the original value by adding the divisor back to the remainder and generate a 0 in the quotient (step 2b). The divisor is shifted right, and then we iterate again. The remainder and quotient will be found in their namesake registers after the iterations complete.

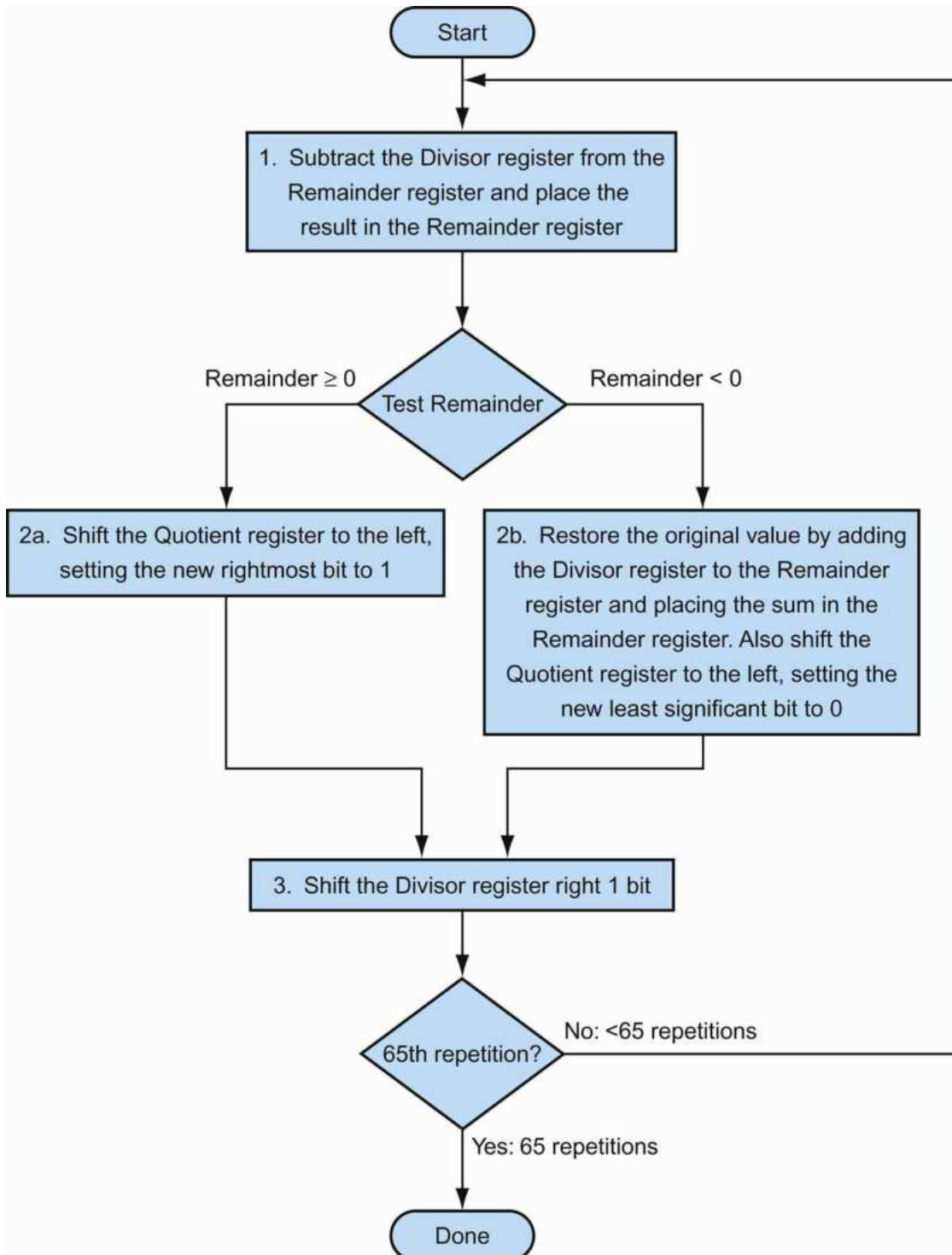

FIGURE 3.9 A division algorithm, using the hardware in [Figure 3.8](#).

If the remainder is positive, the divisor did go into the dividend, so step 2a generates a 1 in the quotient. A negative remainder after step 1 means that the divisor did not go into the dividend, so step 2b generates a 0 in the quotient and adds the divisor to the remainder, thereby reversing the subtraction of step 1. The final

shift, in step 3, aligns the divisor properly, relative to the dividend for the next iteration. These steps are repeated 65 times.

A Divide Algorithm

Example

Using a 4-bit version of the algorithm to save pages, let's try dividing 7_{ten} by 2_{ten} , or $0000\ 0111_{\text{two}}$ by 0010_{two} .

Answer

Figure 3.10 shows the value of each register for each of the steps, with the quotient being 3_{ten} and the remainder 1_{ten} . Notice that the test in step 2 of whether the remainder is positive or negative simply checks whether the sign bit of the Remainder register is a 0 or 1. The surprising requirement of this algorithm is that it takes $n + 1$ steps to get the proper quotient and remainder.

Iteration	Step	Quotient	Divisor	Remainder
0	Initial values	0000	0010 0000	0000 0111
1	1: Rem = Rem - Div	0000	0010 0000	⓪110 0111
	2b: Rem < 0 ⇒ +Div, SLL Q, Q0 = 0	0000	0010 0000	0000 0111
	3: Shift Div right	0000	0001 0000	0000 0111
2	1: Rem = Rem - Div	0000	0001 0000	⓪111 0111
	2b: Rem < 0 ⇒ +Div, SLL Q, Q0 = 0	0000	0001 0000	0000 0111
	3: Shift Div right	0000	0000 1000	0000 0111
3	1: Rem = Rem - Div	0000	0000 1000	⓪111 1111
	2b: Rem < 0 ⇒ +Div, SLL Q, Q0 = 0	0000	0000 1000	0000 0111
	3: Shift Div right	0000	0000 0100	0000 0111
4	1: Rem = Rem - Div	0000	0000 0100	⓪000 0011
	2a: Rem ≥ 0 ⇒ SLL Q, Q0 = 1	0001	0000 0100	0000 0011
	3: Shift Div right	0001	0000 0010	0000 0011
5	1: Rem = Rem - Div	0001	0000 0010	⓪000 0001
	2a: Rem ≥ 0 ⇒ SLL Q, Q0 = 1	0011	0000 0010	0000 0001
	3: Shift Div right	0011	0000 0001	0000 0001

FIGURE 3.10 Division example using the algorithm in Figure 3.9.

The bit examined to determine the next step is circled in color.

This algorithm and hardware can be refined to be faster and cheaper. The speed-up comes from shifting the operands and the quotient simultaneously with the subtraction. This refinement halves the width of the adder and registers by noticing where there are unused portions of registers and adders. [Figure 3.11](#) shows the revised hardware.

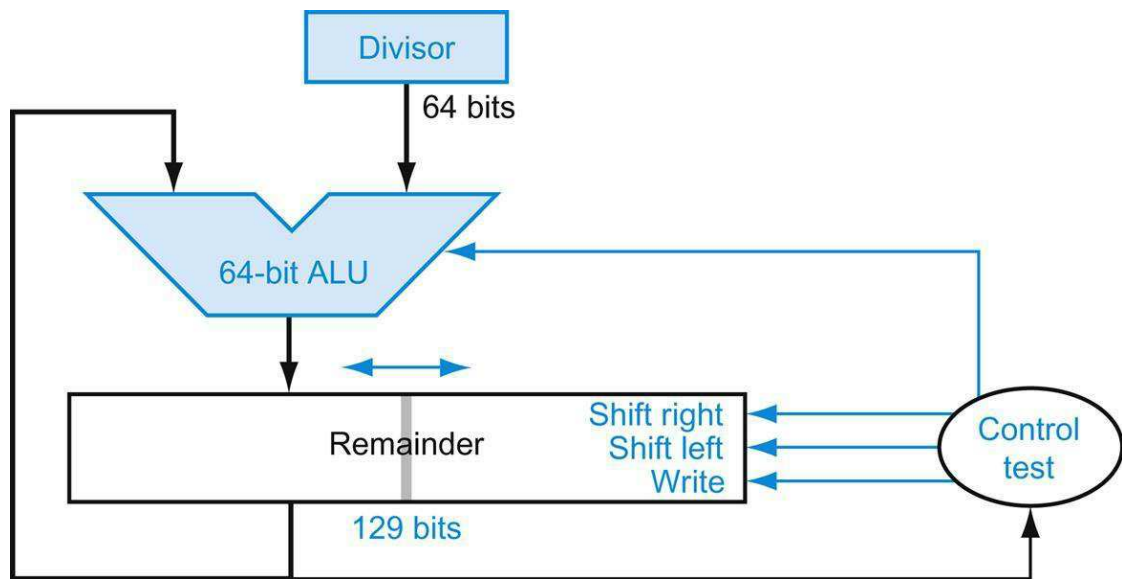

FIGURE 3.11 An improved version of the division hardware.

The Divisor register, ALU, and Quotient register are all 64 bits wide. Compared to [Figure 3.8](#), the ALU and Divisor registers are halved and the remainder is shifted left. This version also combines the Quotient register with the right half of the Remainder register. As in [Figure 3.5](#), the Remainder register has grown to 129 bits to make sure the carry out of the adder is not lost.

Signed Division

So far, we have ignored signed numbers in division. The simplest solution is to remember the signs of the divisor and dividend and then negate the quotient if the signs disagree.

Elaboration

The one complication of signed division is that we must also set the

sign of the remainder. Remember that the following equation must always hold:

$$\text{Dividend} = \text{Quotient} \times \text{Divisor} + \text{Remainder}$$

To understand how to set the sign of the remainder, let's look at the example of dividing all the combinations of $\pm 7_{\text{ten}}$ by $\pm 2_{\text{ten}}$. The first case is easy:

$$+7 \div +2: \text{Quotient} = +3, \text{Remainder} = +1$$

Checking the results:

$$+7 = 3 \times 2 + (+1) = 6 + 1$$

If we change the sign of the dividend, the quotient must change as well:

$$-7 \div +2: \text{Quotient} = -3$$

Rewriting our basic formula to calculate the remainder:

$$\begin{aligned} \text{Remainder} &= (\text{Dividend} - \text{Quotient} \times \text{Divisor}) = -7 - (-3 \times 2) \\ &= -7 - (-6) = -1 \end{aligned}$$

So,

$$-7 \div +2: \text{Quotient} = -3, \text{Remainder} = -1$$

Checking the results again:

$$-7 = -3 \times 2 + (-1) = -6 - 1$$

The reason the answer isn't a quotient of -4 and a remainder of $+1$, which would also fit this formula, is that the absolute value of the quotient would then change depending on the sign of the

dividend and the divisor! Clearly, if

$$-(x \div y) \neq (-x) \div y$$

programming would be an even greater challenge. This anomalous behavior is avoided by following the rule that the dividend and remainder must have identical signs, no matter what the signs of the divisor and quotient.

We calculate the other combinations by following the same rule:

$$\begin{aligned} +7 \div -2: \text{Quotient} = -3, \text{Remainder} = +1 \\ -7 \div -2: \text{Quotient} = +3, \text{Remainder} = -1 \end{aligned}$$

Thus, the correctly signed division algorithm negates the quotient if the signs of the operands are opposite and makes the sign of the nonzero remainder match the dividend.

Faster Division

Moore's Law applies to division hardware as well as multiplication, so we would like to be able to speed up division by throwing hardware at it. We used many adders to speed up multiply, but we cannot do the same trick for divide. The reason is that we need to know the sign of the difference before we can perform the next step of the algorithm, whereas with multiply we could calculate the 64 partial products immediately.

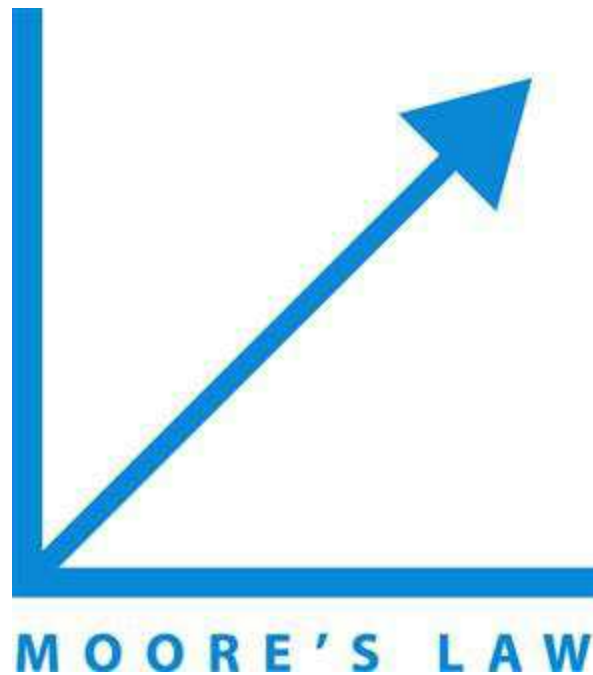

There are techniques to produce more than one bit of the quotient per step. The *SRT division* technique tries to **predict** several quotient bits per step, using a table lookup based on the upper bits of the dividend and remainder. It relies on subsequent steps to correct wrong predictions. A typical value today is 4 bits. The key is guessing the value to subtract. With binary division, there is only a single choice. These algorithms use 6 bits from the remainder and 4 bits from the divisor to index a table that determines the guess for each step.



PREDICTION

The accuracy of this fast method depends on having proper values in the lookup table. The *Fallacy* on page 224 in [Section 3.8](#) shows what can happen if the table is incorrect.

Divide in RISC-V

You may have already observed that the same sequential hardware can be used for both multiply and divide in [Figures 3.5](#) and [3.11](#). The only requirement is a 128-bit register that can shift left or right and a 64-bit ALU that adds or subtracts.

To handle both signed integers and unsigned integers, RISC-V has two instructions for division and two instructions for remainder: *divide* (`div`), *divide unsigned* (`divu`), *remainder* (`rem`), and *remainder unsigned* (`remu`).

Summary

The common hardware support for multiply and divide allows RISC-V to provide a single pair of 64-bit registers that are used both for multiply and divide. We accelerate division by predicting

multiple quotient bits and then correcting mispredictions later. Figure 3.12 summarizes the enhancements to the RISC-V architecture for the last two sections.

Hardware/Software Interface

RISC-V divide instructions ignore overflow, so software must determine whether the quotient is too large. In addition to overflow, division can also result in an improper calculation: division by 0. Some computers distinguish these two anomalous events. RISC-V software must check the divisor to discover division by 0 as well as overflow.

Elaboration

An even faster algorithm does not immediately add the divisor back if the remainder is negative. It simply *adds* the dividend to the shifted remainder in the following step, since $(r+d) \times 2 - d = r \times 2 + d$. This *nonrestoring* division algorithm, which takes one clock cycle per step, is explored further in the exercises; the algorithm above is called *restoring* division. A third algorithm that doesn't save the result of the subtract if it's negative is called a *nonperforming* division algorithm. It averages one-third fewer arithmetic operations.

RISC-V assembly language

Category	Instruction	Example	Meaning	Comments
Arithmetic	Add	add x5, x6, x7	$x5 = x6 + x7$	Three register operands
	Subtract	sub x5, x6, x7	$x5 = x6 - x7$	Three register operands
	Add immediate	addi x5, x6, 20	$x5 = x6 + 20$	Used to add constants
	Set if less than	slt x5, x6, x7	$x5 = 1 \text{ if } x5 < x6, \text{ else } 0$	Three register operands
	Set if less than, unsigned	sltu x5, x6, x7	$x5 = 1 \text{ if } x5 < x6, \text{ else } 0$	Three register operands
	Set if less than, immediate	slti x5, x6, 20	$x5 = 1 \text{ if } x5 < 20, \text{ else } 0$	Comparison with immediate
	Set if less than immediate, uns.	sltiu x5, x6, 20	$x5 = 1 \text{ if } x5 < 20, \text{ else } 0$	Comparison with immediate
	Multiply	mul x5, x6, x7	$x5 = x6 \times x7$	Lower 64 bits of 128-bit product
	Multiply high	mulh x5, x6, x7	$x5 = (x6 \times x7) \gg 64$	Upper 64 bits of 128-bit signed product
	Multiply high, unsigned	mulhu x5, x6, x7	$x5 = (x6 \times x7) \gg 64$	Upper 64 bits of 128-bit unsigned product
	Multiply high, signed-unsigned	mulhsu x5, x6, x7	$x5 = (x6 \times x7) \gg 64$	Upper 64 bits of 128-bit signed-unsigned product
	Divide	div x5, x6, x7	$x5 = x6 / x7$	Divide signed 64-bit numbers
	Divide unsigned	divu x5, x6, x7	$x5 = x6 / x7$	Divide unsigned 64-bit numbers
	Remainder	rem x5, x6, x7	$x5 = x6 \% x7$	Remainder of signed 64-bit division
Remainder unsigned	remu x5, x6, x7	$x5 = x6 \% x7$	Remainder of unsigned 64-bit division	
Data transfer	Load doubleword	ld x5, 40(x6)	$x5 = \text{Memory}[x6 + 40]$	Doubleword from memory to register
	Store doubleword	sd x5, 40(x6)	$\text{Memory}[x6 + 40] = x5$	Doubleword from register to memory
	Load word	lw x5, 40(x6)	$x5 = \text{Memory}[x6 + 40]$	Word from memory to register
	Load word, unsigned	lwu x5, 40(x6)	$x5 = \text{Memory}[x6 + 40]$	Unsigned word from memory to register
	Store word	sw x5, 40(x6)	$\text{Memory}[x6 + 40] = x5$	Word from register to memory
	Load halfword	lh x5, 40(x6)	$x5 = \text{Memory}[x6 + 40]$	Halfword from memory to register
	Load halfword, unsigned	lhu x5, 40(x6)	$x5 = \text{Memory}[x6 + 40]$	Unsigned halfword from memory to register
	Store halfword	sh x5, 40(x6)	$\text{Memory}[x6 + 40] = x5$	Halfword from register to memory
	Load byte	lb x5, 40(x6)	$x5 = \text{Memory}[x6 + 40]$	Byte from memory to register
	Load byte, unsigned	lbu x5, 40(x6)	$x5 = \text{Memory}[x6 + 40]$	Byte halfword from memory to register
	Store byte	sb x5, 40(x6)	$\text{Memory}[x6 + 40] = x5$	Byte from register to memory
	Load reserved	lr.d x5, (x6)	$x5 = \text{Memory}[x6]$	Load; 1st half of atomic swap
	Store conditional	sc.d x7, x5, (x6)	$\text{Memory}[x6] = x5; x7 = 0/1$	Store; 2nd half of atomic swap
	Load upper immediate	lui x5, 0x12345	$x5 = 0x12345000$	Loads 20-bit constant shifted left 12 bits
Add upper immediate to PC	auipc x5, 0x12345	$x5 = \text{PC} + 0x12345000$	Used for PC-relative data addressing	
Logical	And	and x5, x6, x7	$x5 = x6 \& x7$	Three reg. operands; bit-by-bit AND
	Inclusive or	or x5, x6, x8	$x5 = x6 x8$	Three reg. operands; bit-by-bit OR
	Exclusive or	xor x5, x6, x9	$x5 = x6 \wedge x9$	Three reg. operands; bit-by-bit XOR
	And immediate	andi x5, x6, 20	$x5 = x6 \& 20$	Bit-by-bit AND reg. with constant
	Inclusive or immediate	ori x5, x6, 20	$x5 = x6 20$	Bit-by-bit OR reg. with constant
	Exclusive or immediate	xori x5, x6, 20	$x5 = x6 \wedge 20$	Bit-by-bit XOR reg. with constant
Shift	Shift left logical	sll x5, x6, x7	$x5 = x6 \ll x7$	Shift left by register
	Shift right logical	srl x5, x6, x7	$x5 = x6 \gg x7$	Shift right by register
	Shift right arithmetic	sra x5, x6, x7	$x5 = x6 \gg x7$	Arithmetic shift right by register
	Shift left logical immediate	slli x5, x6, 3	$x5 = x6 \ll 3$	Shift left by immediate
	Shift right logical immediate	srl_i x5, x6, 3	$x5 = x6 \gg 3$	Shift right by immediate
	Shift right arithmetic immediate	sra_i x5, x6, 3	$x5 = x6 \gg 3$	Arithmetic shift right by immediate
Conditional branch	Branch if equal	beq x5, x6, 100	if $(x5 == x6)$ go to PC+100	PC-relative branch if registers equal
	Branch if not equal	bne x5, x6, 100	if $(x5 != x6)$ go to PC+100	PC-relative branch if registers not equal
	Branch if less than	blt x5, x6, 100	if $(x5 < x6)$ go to PC+100	PC-relative branch if registers less
	Branch if greater or equal	bge x5, x6, 100	if $(x5 \geq x6)$ go to PC+100	PC-relative branch if registers greater or equal
	Branch if less, unsigned	bltu x5, x6, 100	if $(x5 < x6)$ go to PC+100	PC-relative branch if registers less
	Branch if greatr/eq, unsigned	bgeu x5, x6, 100	if $(x5 \geq x6)$ go to PC+100	PC-relative branch if registers greater or equal
Unconditional branch	Jump and link	jal x1, 100	$x1 = \text{PC}+4$; go to PC+100	PC-relative procedure call
	Jump and link register	jalr x1, 100(x5)	$x1 = \text{PC}+4$; go to $x5+100$	Procedure return; indirect call

FIGURE 3.12 RISC-V core architecture.
RISC-V machine language is listed in the RISC-V Reference Data Card at the front of this book.

3.5 Floating Point

Going beyond signed and unsigned integers, programming languages support numbers with fractions, which are called *reals* in mathematics. Here are some examples of reals:

Speed gets you nowhere if you're headed the wrong way.

American proverb

$3.14159265\dots_{\text{ten}}$ (π)

$2.71828\dots_{\text{ten}}$ (e)

0.000000001_{ten} or $1.0_{\text{ten}} \times 10^{-9}$ (seconds in a nanosecond)

$3,155,760,000_{\text{ten}}$ or $3.15576_{\text{ten}} \times 10^9$ (seconds in a typical century)

Notice that in the last case, the number didn't represent a small fraction, but it was bigger than we could represent with a 32-bit signed integer. The alternative notation for the last two numbers is called **scientific notation**, which has a single digit to the left of the decimal point. A number in scientific notation that has no leading 0s is called a **normalized** number, which is the usual way to write it. For example, $1.0_{\text{ten}} \times 10^{-9}$ is in normalized scientific notation, but $0.1_{\text{ten}} \times 10^{-8}$ and $10.0_{\text{ten}} \times 10^{-10}$ are not.

scientific notation

A notation that renders numbers with a single digit to the left of the decimal point.

normalized

A number in floating-point notation that has no leading 0s.

Just as we can show decimal numbers in scientific notation, we can also show binary numbers in scientific notation:

$$1.0_{\text{two}} \times 2^{-1}$$

To keep a binary number in the normalized form, we need a base that we can increase or decrease by exactly the number of bits the

number must be shifted to have one nonzero digit to the left of the decimal point. Only a base of 2 fulfills our need. Since the base is not 10, we also need a new name for decimal point; *binary point* will do fine.

Computer arithmetic that supports such numbers is called **floating point** because it represents numbers in which the binary point is not fixed, as it is for integers. The programming language C uses the name *float* for such numbers. Just as in scientific notation, numbers are represented as a single nonzero digit to the left of the binary point. In binary, the form is

$$1.\text{xxxxxxxx}_{\text{two}} \times 2^{\text{yyyy}}$$

(Although the computer represents the exponent in base 2 as well as the rest of the number, to simplify the notation we show the exponent in decimal.)

floating point

Computer arithmetic that represents numbers in which the binary point is not fixed.

A standard scientific notation for reals in the normalized form offers three advantages. It simplifies exchange of data that includes floating-point numbers; it simplifies the floating-point arithmetic algorithms to know that numbers will always be in this form; and it increases the accuracy of the numbers that can be stored in a word, since real digits to the right of the binary point replace the unnecessary leading 0s.

Floating-Point Representation

A designer of a floating-point representation must find a compromise between the size of the **fraction** and the size of the **exponent**, because a fixed word size means you must take a bit from one to add a bit to the other. This tradeoff is between precision and range: increasing the size of the fraction enhances the precision of the fraction, while increasing the size of the exponent increases the range of numbers that can be represented. As our design

guideline from [Chapter 2](#) reminds us, good design demands good compromise.

fraction

The value, generally between 0 and 1, placed in the fraction field. The fraction is also called the *mantissa*.

exponent

In the numerical representation system of floating-point arithmetic, the value that is placed in the exponent field.

Floating-point numbers are usually a multiple of the size of a word. The representation of a RISC-V floating-point number is shown below, where *s* is the sign of the floating-point number (1 meaning negative), *exponent* is the value of the 8-bit exponent field (including the sign of the exponent), and *fraction* is the 23-bit number. As we recall from [Chapter 2](#), this representation is *sign and magnitude*, since the sign is a separate bit from the rest of the number.

31	30	29	28	27	26	25	24	23	22	21	20	19	18	17	16	15	14	13	12	11	10	9	8	7	6	5	4	3	2	1	0
s	exponent								fraction																						
1 bit	8 bits								23 bits																						

In general, floating-point numbers are of the form

$$(-1)^S \times F \times 2^E$$

F involves the value in the fraction field and E involves the value in the exponent field; the exact relationship to these fields will be spelled out soon. (We will shortly see that RISC-V does something slightly more sophisticated.)

These chosen sizes of exponent and fraction give RISC-V computer arithmetic an extraordinary range. Fractions almost as small as $2.0_{\text{ten}} \times 10^{-38}$ and numbers almost as large as $2.0_{\text{ten}} \times 10^{38}$ can be represented in a computer. Alas, extraordinary differs from infinite, so it is still possible for numbers to be too large. Thus,

overflow interrupts can occur in floating-point arithmetic as well as in integer arithmetic. Notice that **overflow** here means that the exponent is too large to be represented in the exponent field.

overflow (floating-point)

A situation in which a positive exponent becomes too large to fit in the exponent field.

Floating point offers a new kind of exceptional event as well. Just as programmers will want to know when they have calculated a number that is too large to be represented, they will want to know if the nonzero fraction they are calculating has become so small that it cannot be represented; either event could result in a program giving incorrect answers. To distinguish it from overflow, we call this event **underflow**. This situation occurs when the negative exponent is too large to fit in the exponent field.

underflow (floating-point)

A situation in which a negative exponent becomes too large to fit in the exponent field.

One way to reduce the chances of underflow or overflow is to offer another format that has a larger exponent. In C, this number is called *double*, and operations on doubles are called **double precision** floating-point arithmetic; **single precision** floating point is the name of the earlier format.

double precision

A floating-point value represented in a 64-bit doubleword.

single precision

A floating-point value represented in a 32-bit word.

The representation of a double precision floating-point number takes one RISC-V doubleword, as shown below, where *s* is still the sign of the number, *exponent* is the value of the 11-bit exponent field, and *fraction* is the 52-bit number in the fraction field.

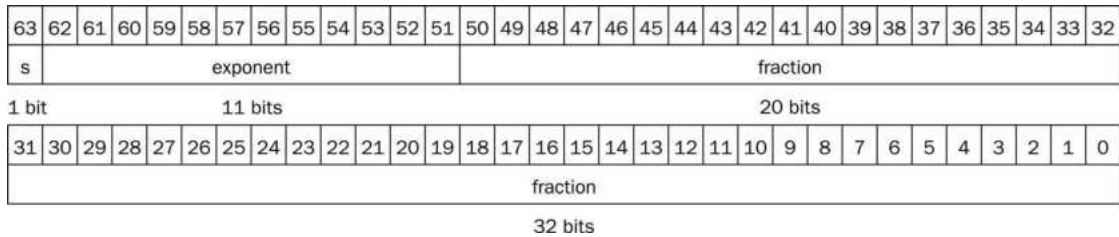

RISC-V double precision allows numbers almost as small as $2.0_{\text{ten}} \times 10^{-308}$ and almost as large as $2.0_{\text{ten}} \times 10^{308}$. Although double precision does increase the exponent range, its primary advantage is its greater precision because of the much larger fraction.

Exceptions and Interrupts

What should happen on an overflow or underflow to let the user know that a problem occurred? Some computers signal these events by raising an **exception**, sometimes called an **interrupt**. An exception or interrupt is essentially an unscheduled procedure call. The address of the instruction that overflowed is saved in a register, and the computer jumps to a predefined address to invoke the appropriate routine for that exception. The interrupted address is saved so that in some situations the program can continue after corrective code is executed. (Section 4.9 covers exceptions in more detail; Chapter 5 describes other situations where exceptions and interrupts occur.) RISC-V computers do *not* raise an exception on overflow or underflow; instead, software can read the *floating-point control and status register* (fcsr) to check whether overflow or underflow has occurred.

exception

Also called **interrupt**. An unscheduled event that disrupts program execution; used to detect overflow.

interrupt

An exception that comes from outside of the processor. (Some architectures use the term *interrupt* for all exceptions.)

IEEE 754 Floating-Point Standard

These formats go beyond RISC-V. They are part of the *IEEE 754 floating-point standard*, found in virtually every computer invented since 1980. This standard has greatly improved both the ease of porting floating-point programs and the quality of computer arithmetic.

To pack even more bits into the number, IEEE 754 makes the leading 1 bit of normalized binary numbers implicit. Hence, the number is actually 24 bits long in single precision (implied 1 and a 23-bit fraction), and 53 bits long in double precision (1 + 52). To be precise, we use the term *significand* to represent the 24- or 53-bit number that is 1 plus the fraction, and *fraction* when we mean the 23- or 52-bit number. Since 0 has no leading 1, it is given the reserved exponent value 0 so that the hardware won't attach a leading 1 to it.

Thus $00 \dots 00_{\text{two}}$ represents 0; the representation of the rest of the numbers uses the form from before with the hidden 1 added:

$$(-1)^S \times (1 + \text{Fraction}) \times 2^E$$

where the bits of the fraction represent a number between 0 and 1 and E specifies the value in the exponent field, to be given in detail shortly. If we number the bits of the fraction from *left to right* s_1, s_2, s_3, \dots , then the value is

$$(-1)^S \times (1 + (s_1 \times 2^{-1}) + (s_2 \times 2^{-2}) + (s_3 \times 2^{-3}) + (s_4 \times 2^{-4}) + \dots) \times 2^E$$

Figure 3.13 shows the encodings of IEEE 754 floating-point numbers. Other features of IEEE 754 are special symbols to represent unusual events. For example, instead of interrupting on a divide by 0, software can set the result to a bit pattern representing $+\infty$ or $-\infty$; the largest exponent is reserved for these special symbols. When the programmer prints the results, the program will output an infinity symbol. (For the mathematically trained, the purpose of infinity is to form topological closure of the reals.)

Single precision		Double precision		Object represented
Exponent	Fraction	Exponent	Fraction	
0	0	0	0	0
0	Nonzero	0	Nonzero	± denormalized number
1–254	Anything	1–2046	Anything	± floating-point number
255	0	2047	0	± infinity
255	Nonzero	2047	Nonzero	NaN (Not a Number)

FIGURE 3.13 IEEE 754 encoding of floating-point numbers.

A separate sign bit determines the sign. Denormalized numbers are described in the *Elaboration* on page 216. This information is also found in Column 4 of the RISC-V Reference Data Card at the front of this book.

IEEE 754 even has a symbol for the result of invalid operations, such as 0/0 or subtracting infinity from infinity. This symbol is *NaN*, for *Not a Number*. The purpose of NaNs is to allow programmers to postpone some tests and decisions to a later time in the program when they are convenient.

The designers of IEEE 754 also wanted a floating-point representation that could be easily processed by integer comparisons, especially for sorting. This desire is why the sign is in the most significant bit, allowing a quick test of less than, greater than, or equal to 0. (It's a little more complicated than a simple integer sort, since this notation is essentially sign and magnitude rather than two's complement.)

Placing the exponent before the significand also simplifies the sorting of floating-point numbers using integer comparison instructions, since numbers with bigger exponents look larger than numbers with smaller exponents, as long as both exponents have the same sign.

Negative exponents pose a challenge to simplified sorting. If we use two's complement or any other notation in which negative exponents have a 1 in the most significant bit of the exponent field, a negative exponent will look like a big number. For example, $1.0_{\text{two}} \times 2^{-1}$ would be represented in a single precision as

31	30	29	28	27	26	25	24	23	22	21	20	19	18	17	16	15	14	13	12	11	10	9	8	7	6	5	4	3	2	1	0
●	1	1	1	1	1	1	1	1	0	0	0	0	0	0	0	0	0	0	0	0	0	0	0	0	0	0	0	0	0	0	0

(Remember that the leading 1 is implicit in the significand.) The value $1.0_{\text{two}} \times 2^{+1}$ would look like the smaller binary number

31	30	29	28	27	26	25	24	23	22	21	20	19	18	17	16	15	14	13	12	11	10	9	8	7	6	5	4	3	2	1	0
0	0	0	0	0	0	0	0	1	0	0	0	0	0	0	0	0	0	0	0	0	0	0	0	0	0	0	0	0	0	0	0

The desirable notation must therefore represent the most negative exponent as $00 \dots 00_{\text{two}}$ and the most positive as $11 \dots 11_{\text{two}}$. This convention is called *biased notation*, with the bias being the number subtracted from the normal, unsigned representation to determine the real value.

IEEE 754 uses a bias of 127 for single precision, so an exponent of -1 is represented by the bit pattern of the value $-1 + 127_{\text{ten}}$, or $126_{\text{ten}} = 0111\ 1110_{\text{two}}$, and $+1$ is represented by $1 + 127$, or $128_{\text{ten}} = 1000\ 0000_{\text{two}}$. The exponent bias for double precision is 1023. Biased exponent means that the value represented by a floating-point number is really

$$(-1)^S \times (1 + \text{Fraction}) \times 2^{(\text{Exponent} - \text{Bias})}$$

The range of single precision numbers is then from as small as

$$\pm 1.00000000000000000000000_{\text{two}} \times 2^{-126}$$

to as large as

$$\pm 1.11111111111111111111111_{\text{two}} \times 2^{+127}$$

Let's demonstrate.

Example

Show the IEEE 754 binary representation of the number -0.75_{ten} in single and double precision.

Answer

The number -0.75_{ten} is also

$$-3/4_{\text{ten}} \text{ or } -3/2^2_{\text{ten}}$$

It is also represented by the binary fraction

$$-11_{\text{two}}/2^2_{\text{ten}} \text{ or } -0.11_{\text{two}}$$

In scientific notation, the value is

$$-0.11_{\text{two}} \times 2^0$$

and in normalized scientific notation, it is

$$-1.1_{\text{two}} \times 2^{-1}$$

The general representation for a single precision number is

$$(-1)^S \times (1 + \text{Fraction}) \times 2^{(\text{Exponent}-127)}$$

Subtracting the bias 127 from the exponent of $-1.1_{\text{two}} \times 2^{-1}$ yields

$$(-1)^1 \times (1 + .1000\ 0000\ 0000\ 0000\ 0000\ 000_{\text{two}}) \times 2^{(126-127)}$$

The single precision binary representation of -0.75_{ten} is then

31	30	29	28	27	26	25	24	23	22	21	20	19	18	17	16	15	14	13	12	11	10	9	8	7	6	5	4	3	2	1	0
1	0	1	1	1	1	1	0	1	0	0	0	0	0	0	0	0	0	0	0	0	0	0	0	0	0	0	0	0	0	0	0
1 bit	8 bits								23 bits																						

The double precision representation is

Elaboration

Following IEEE guidelines, the IEEE 754 committee was reformed 20 years after the standard to see what changes, if any, should be made. The revised standard IEEE 754-2008 includes nearly all the IEEE 754-1985 and adds a 16-bit format (“half precision”) and a 128-bit format (“quadruple precision”). The revised standard also adds decimal floating point arithmetic.

Elaboration

In an attempt to increase range without removing bits from the significand, some computers before the IEEE 754 standard used a base other than 2. For example, the IBM 360 and 370 mainframe computers use base 16. Since changing the IBM exponent by one means shifting the significand by 4 bits, “normalized” base 16 numbers can have up to 3 leading bits of 0s! Hence, hexadecimal digits mean that up to 3 bits must be dropped from the significand, which leads to surprising problems in the accuracy of floating-point arithmetic. IBM mainframes now support IEEE 754 as well as the old hex format.

Floating-Point Addition

Let’s add numbers in scientific notation by hand to illustrate the problems in floating-point addition: $9.999_{\text{ten}} \times 10^1 + 1.610_{\text{ten}} \times 10^{-1}$.

Assume that we can store only four decimal digits of the significand and two decimal digits of the exponent.

Step 1. To be able to add these numbers properly, we must align the decimal point of the number that has the smaller exponent.

Hence, we need a form of the smaller number, $1.610_{\text{ten}} \times 10^{-1}$, that matches the larger exponent. We obtain this by observing that there are multiple representations of an unnormalized floating-point number in scientific notation:

$$1.610_{\text{ten}} \times 10^{-1} = 0.1610_{\text{ten}} \times 10^0 = 0.01610_{\text{ten}} \times 10^1$$

The number on the right is the version we desire, since its exponent matches the exponent of the larger number, $9.999_{\text{ten}} \times 10^1$. Thus, the first step shifts the

significand of the smaller number to the right until its corrected exponent matches that of the larger number. But we can represent only four decimal digits so, after shifting, the number is really

$$0.016 \times 10^1$$

Step 2. Next comes the addition of the significands:

$$\begin{array}{r} 9.999_{\text{ten}} \\ + 0.016_{\text{ten}} \\ \hline 10.015_{\text{ten}} \end{array}$$

The sum is $10.015_{\text{ten}} \times 10^1$.

Step 3. This sum is not in normalized scientific notation, so we need to adjust it:

$$10.015_{\text{ten}} \times 10^1 = 1.0015_{\text{ten}} \times 10^2$$

Thus, after the addition we may have to shift the sum to put it into normalized form, adjusting the exponent appropriately. This example shows shifting to the right, but if one number were positive and the other were negative, it would be possible for the sum to have many leading 0s, requiring left shifts. Whenever the exponent is increased or decreased, we must check for overflow or underflow—that is, we must make sure that the exponent still fits in its field.

Step 4. Since we assumed that the significand could be only four digits long (excluding the sign), we must round the number. In our grammar school algorithm, the rules truncate the number if the digit to the right of the desired point is between 0 and 4 and add 1 to the digit if the number to the right is between 5 and 9. The number

$$1.0015_{\text{ten}} \times 10^2$$

is rounded to four digits in the significand to

$$1.002_{\text{ten}} \times 10^2$$

since the fourth digit to the right of the decimal point was between 5 and 9. Notice that if we have bad luck on rounding, such as adding 1 to a string of 9s, the sum may no longer be normalized and we would need to perform step 3 again.

Figure 3.14 shows the algorithm for binary floating-point addition that follows this decimal example. Steps 1 and 2 are similar to the example just discussed: adjust the significand of the number with the smaller exponent and then add the two significands. Step 3 normalizes the results, forcing a check for overflow or underflow. The test for overflow and underflow in step 3 depends on the precision of the operands. Recall that the pattern of all 0 bits in the exponent is reserved and used for the floating-point representation of zero. Moreover, the pattern of all 1 bits in the exponent is reserved for indicating values and situations outside the scope of normal floating-point numbers (see the *Elaboration* on page 216). For the example below, remember that for single precision, the maximum exponent is 127, and the minimum exponent is -126.

Binary Floating-Point Addition

Example

Try adding the numbers 0.5_{ten} and -0.4375_{ten} in binary using the algorithm in Figure 3.14.

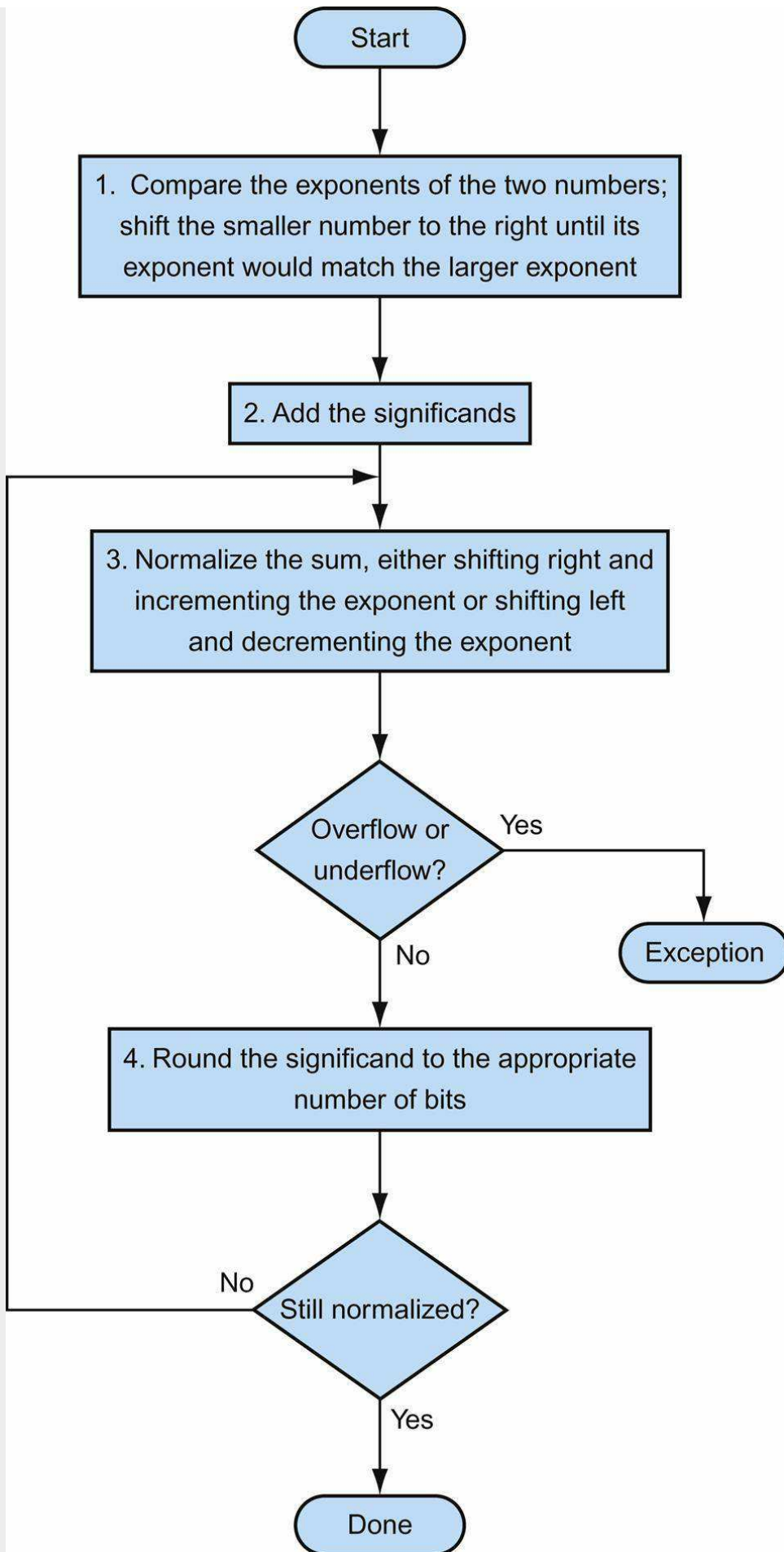

FIGURE 3.14 Floating-point addition.

The normal path is to execute steps 3 and 4 once, but if rounding causes the sum to be unnormalized, we must repeat step 3.

Answer

Let's first look at the binary version of the two numbers in normalized scientific notation, assuming that we keep 4 bits of precision:

$$\begin{aligned} 0.5_{\text{ten}} &= 1/2_{\text{ten}} &= 1/2^1_{\text{ten}} && && \\ &= 0.1_{\text{two}} &= 0.1_{\text{two}} \times 2^0 &= 1.000_{\text{two}} \times 2^{-1} \\ -0.4375_{\text{ten}} &= -7/16_{\text{ten}} &= -7/2^4_{\text{ten}} && && \\ &= -0.0111_{\text{two}} &= -0.0111_{\text{two}} \times 2^0 &= -1.110_{\text{two}} \times 2^{-2} \end{aligned}$$

Now we follow the algorithm:

Step 1. The significand of the number with the lesser exponent ($-1.11_{\text{two}} \times 2^{-2}$) is shifted right until its exponent matches the larger number:

$$-1.110_{\text{two}} \times 2^{-2} = -0.111_{\text{two}} \times 2^{-1}$$

Step 2. Add the significands:

$$1.000_{\text{two}} \times 2^{-1} + (-0.111_{\text{two}} \times 2^{-1}) = 0.001_{\text{two}} \times 2^{-1}$$

Step 3. Normalize the sum, checking for overflow or underflow:

$$\begin{aligned} 0.001_{\text{two}} \times 2^{-1} &= 0.010_{\text{two}} \times 2^{-2} = 0.100_{\text{two}} \times 2^{-3} \\ &= 1.000_{\text{two}} \times 2^{-4} \end{aligned}$$

Since $127 \geq -4 \geq -126$, there is no overflow or underflow. (The biased exponent would be $-4 + 127$, or 123, which is between 1 and 254, the smallest and largest unreserved biased exponents.)

Step 4. Round the sum:

$$1.000_{\text{two}} \times 2^{-4}$$

The sum already fits exactly in 4 bits, so there is no change to the bits due to rounding.

This sum is then

$$\begin{aligned} 1.000_{\text{two}} \times 2^{-4} &= 0.0001000_{\text{two}} = 0.0001_{\text{two}} \\ &= 1/2_{\text{ten}}^4 = 1/16_{\text{ten}} = 0.0625_{\text{ten}} \end{aligned}$$

This sum is what we would expect from adding 0.5_{ten} to -0.4375_{ten} .

Many computers dedicate hardware to run floating-point operations as fast as possible. [Figure 3.15](#) sketches the basic organization of hardware for floating-point addition.

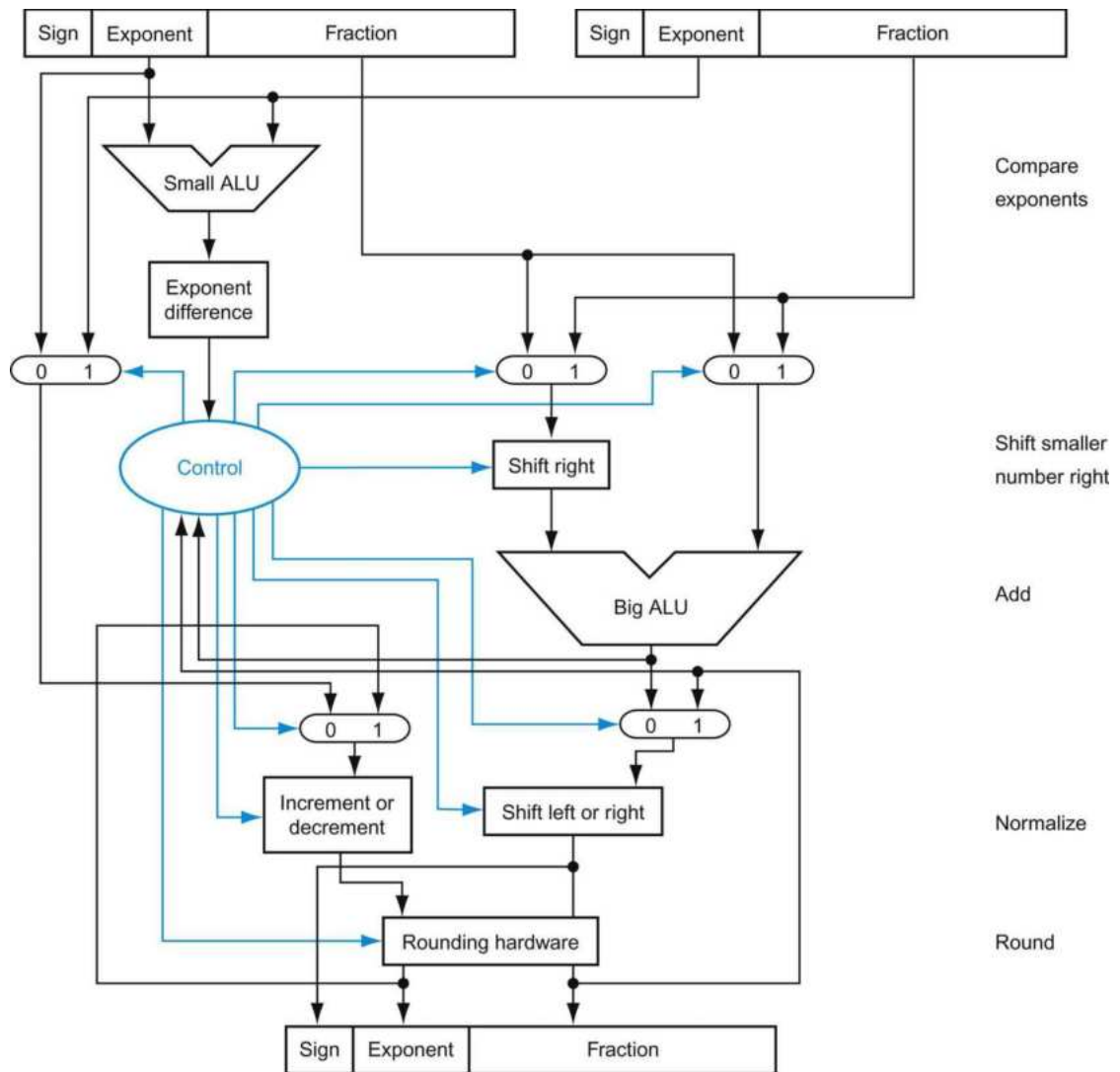

FIGURE 3.15 Block diagram of an arithmetic unit dedicated to floating-point addition.

The steps of Figure 3.14 correspond to each block, from top to bottom. First, the exponent of one operand is subtracted from the other using the small ALU to determine which is larger and by how much. This difference controls the three multiplexors; from left to right, they select the larger exponent, the significand of the smaller number, and the significand of the larger number. The smaller significand is shifted right, and then the significands are added together using the big ALU. The normalization step then shifts the sum left or right and increments or decrements the exponent. Rounding then creates the final result, which may require normalizing again to produce the actual final result.

Floating-Point Multiplication

Now that we have explained floating-point addition, let's try floating-point multiplication. We start by multiplying decimal numbers in scientific notation by hand: $1.110_{\text{ten}} \times 10^{10} \times 9.200_{\text{ten}} \times 10^{-5}$. Assume that we can store only four digits of the significand and two digits of the exponent.

Step 1. Unlike addition, we calculate the exponent of the product by simply adding the exponents of the operands together:

$$\text{New exponent} = 10 + (-5) = 5$$

Let's do this with the biased exponents as well to make sure we obtain the same result: $10 + 127 = 137$, and $-5 + 127 = 122$, so

$$\text{New exponent} = 137 + 122 = 259$$

This result is too large for the 8-bit exponent field, so something is amiss! The problem is with the bias because we are adding the biases as well as the exponents:

$$\text{New exponent} = (10 + 127) + (-5 + 127) = (5 + 2 \times 127) = 259$$

Accordingly, to get the correct biased sum when we add biased numbers, we must subtract the bias from the sum:

$$\text{New exponent} = 137 + 122 - 127 = 259 - 127 = 132 = (5 + 127)$$

and 5 is indeed the exponent we calculated initially.

Step 2. Next comes the multiplication of the significands:

$$\begin{array}{r}
 1.110_{\text{ten}} \\
 \times 9.200_{\text{ten}} \\
 \hline
 0000 \\
 0000 \\
 2220 \\
 9990 \\
 \hline
 1110000_{\text{ten}}
 \end{array}$$

There are three digits to the right of the decimal point for each operand, so the decimal point is placed six digits from the right in the product significand:

$$10.212000_{\text{ten}}$$

If we can keep only three digits to the right of the decimal point, the product is 10.212×10^5 .

Step 3. This product is unnormalized, so we need to normalize it:

$$10.212_{\text{ten}} \times 10^5 = 1.0212_{\text{ten}} \times 10^6$$

Thus, after the multiplication, the product can be shifted right one digit to put it in normalized form, adding 1 to the exponent. At this point, we can check for overflow and underflow. Underflow may occur if both operands are small—that is, if both have large negative exponents.

Step 4. We assumed that the significand is only four digits long (excluding the sign), so we must round the number. The number

$$1.0212_{\text{ten}} \times 10^6$$

is rounded to four digits in the significand to

$$1.021_{\text{ten}} \times 10^6$$

Step 5. The sign of the product depends on the signs of the original operands. If they are both the same, the sign is positive; otherwise, it's negative. Hence, the product is

$$+1.021_{\text{ten}} \times 10^6$$

The sign of the sum in the addition algorithm was determined by addition of the significands, but in multiplication, the signs of the operands determine the sign of the product.

Once again, as [Figure 3.16](#) shows, multiplication of binary floating-point numbers is quite similar to the steps we have just completed. We start with calculating the new exponent of the product by adding the biased exponents, being sure to subtract one bias to get the proper result. Next is multiplication of significands, followed by an optional normalization step. The size of the exponent is checked for overflow or underflow, and then the product is rounded. If rounding leads to further normalization, we once again check for exponent size. Finally, set the sign bit to 1 if the signs of the operands were different (negative product) or to 0 if they were the same (positive product).

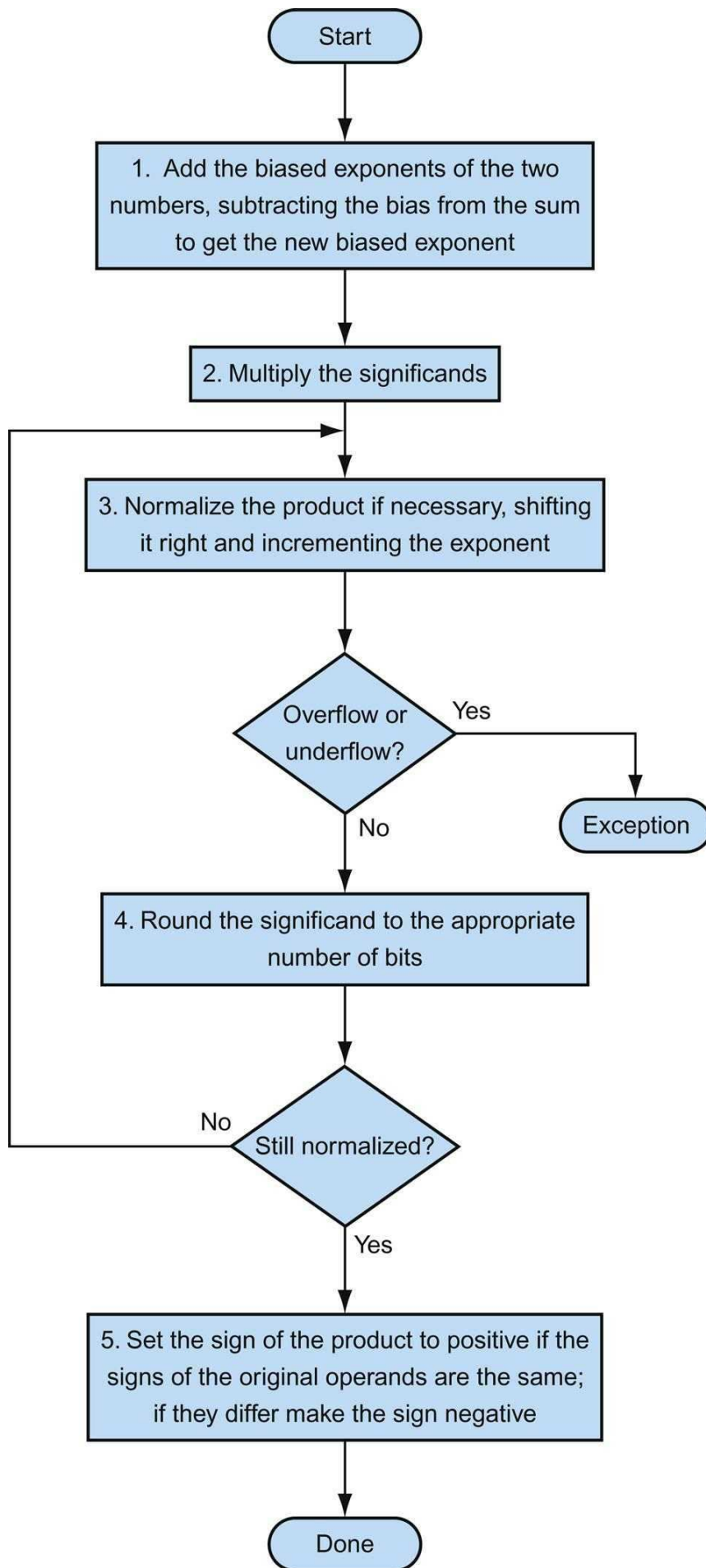

FIGURE 3.16 Floating-point multiplication.

The normal path is to execute steps 3 and 4 once, but if rounding causes the sum to be unnormalized, we must repeat step 3.

Binary Floating-Point Multiplication

Example

Let's try multiplying the numbers 0.5_{ten} and -0.4375_{ten} using the steps in [Figure 3.16](#).

Answer

In binary, the task is multiplying $1.000_{\text{two}} \times 2^{-1}$ by $-1.110_{\text{two}} \times 2^{-2}$.

Step 1. Adding the exponents without bias:

$$-1 + (-2) = -3$$

or, using the biased representation:

$$\begin{aligned} (-1 + 127) + (-2 + 127) - 127 &= (-1 - 2) + (127 + 127 - 127) \\ &= -3 + 127 = 124 \end{aligned}$$

Step 2. Multiplying the significands:

$$\begin{array}{r}
 1.000_{\text{two}} \\
 \times 1.110_{\text{two}} \\
 \hline
 0000 \\
 1000 \\
 1000 \\
 1000 \\
 \hline
 1110000_{\text{two}}
 \end{array}$$

The product is $1.110000_{\text{two}} \times 2^{-3}$, but we need to keep it to 4 bits, so it is $1.110_{\text{two}} \times 2^{-3}$.

Step 3. Now we check the product to make sure it is normalized, and then check the exponent for overflow or underflow. The product is already normalized and, since $127 \geq -3 \geq -126$, there is no overflow or underflow. (Using the biased representation, $254 \geq 124 \geq 1$, so the exponent fits.)

Step 4. Rounding the product makes no change:

$$1.110_{\text{two}} \times 2^{-3}$$

Step 5. Since the signs of the original operands differ, make the sign of the product negative. Hence, the product is

$$-1.110_{\text{two}} \times 2^{-3}$$

Converting to decimal to check our results:

$$\begin{aligned}
 -1.110_{\text{two}} \times 2^{-3} &= -0.001110_{\text{two}} = -0.00111_{\text{two}} \\
 &= -7/2^5_{\text{ten}} = -7/32_{\text{ten}} = -0.21875_{\text{ten}}
 \end{aligned}$$

The product of 0.5_{ten} and -0.4375_{ten} is indeed -0.21875_{ten} .

Floating-Point Instructions in RISC-V

RISC-V supports the IEEE 754 single-precision and double-precision formats with these instructions:

- Floating-point *addition, single* (`fadd.s`) and *addition, double* (`fadd.d`)
- Floating-point *subtraction, single* (`fsub.s`) and *subtraction, double* (`fsub.d`)
- Floating-point *multiplication, single* (`fmul.s`) and *multiplication, double* (`fmul.d`)
- Floating-point *division, single* (`fdiv.s`) and *division, double* (`fdiv.d`)
- Floating-point square root, *single* (`fsqrt.s`) and *square root, double* (`fsqrt.d`)
- Floating-point equals, *single* (`feq.s`) and *equals, double* (`feq.d`)
- Floating-point less-than, *single* (`flt.s`) and *less-than, double* (`flt.d`)
- Floating-point less-than-or-equals, *single* (`fle.s`) and *less-than-or-equals, double* (`fle.d`)

The comparison instructions, `feq`, `flt`, and `fle`, set an integer register to 0 if the comparison is false and 1 if it is true. Software can thus branch on the result of a floating-point comparison using the integer branch instructions `beq` and `bne`.

The RISC-V designers decided to add separate floating-point registers. They are called `f0`, `f1`, ..., `f31`. Hence, they included separate loads and stores for floating-point registers: `fld` and `fsd` for double-precision and `flw` and `fsw` for single-precision. The base registers for floating-point data transfers which are used for addresses remain integer registers. The RISC-V code to load two single precision numbers from memory, add them, and then store the sum might look like this:

```

flw f0, 0(x10) // Load 32-bit F.P. number into f0
flw f1, 4(x10) // Load 32-bit F.P. number into f1
fadd.s f2, f0, f1 // f2 = f0 + f1, single precision
fsw f2, 8(x10) // Store 32-bit F.P. number from f2

```

A single precision register is just the lower half of a double-precision register. Note that, unlike integer register x_0 , floating-point register f_0 is *not* hard-wired to the constant 0.

Figure 3.17 summarizes the floating-point portion of the RISC-V architecture revealed in this chapter, with the new pieces to support floating point shown in color. The floating-point instructions use the same format as their integer counterparts: loads use the I-type format, stores use the S-type format, and arithmetic instructions use the R-type format.

RISC-V floating-point operands				
Name	Example	Comments		
32 floating-point registers	f_0-f_{31}	An f -register can hold either a single-precision floating-point number or a double-precision floating-point number.		
2^{61} memory double words	Memory[0], Memory[8], ... Memory[18,446,744,073,709,551,608]	Accessed only by data transfer instructions. RISC-V uses byte addresses, so sequential doubleword accesses differ by 8. Memory holds data structures, arrays, and spilled registers.		

RISC-V floating-point assembly language				
Category	Instruction	Example	Meaning	Comments
Arithmetic	FP add single	<code>fadd.s f0, f1, f2</code>	$f_0 = f_1 + f_2$	FP add (single precision)
	FP subtract single	<code>fsub.s f0, f1, f2</code>	$f_0 = f_1 - f_2$	FP subtract (single precision)
	FP multiply single	<code>fmul.s f0, f1, f2</code>	$f_0 = f_1 * f_2$	FP multiply (single precision)
	FP divide single	<code>fdiv.s f0, f1, f2</code>	$f_0 = f_1 / f_2$	FP divide (single precision)
	FP square root single	<code>fsqrt.s f0, f1</code>	$f_0 = \sqrt{f_1}$	FP square root (single precision)
	FP add double	<code>fadd.d f0, f1, f2</code>	$f_0 = f_1 + f_2$	FP add (double precision)
	FP subtract double	<code>fsub.d f0, f1, f2</code>	$f_0 = f_1 - f_2$	FP subtract (double precision)
	FP multiply double	<code>fmul.d f0, f1, f2</code>	$f_0 = f_1 * f_2$	FP multiply (double precision)
	FP divide double	<code>fdiv.d f0, f1, f2</code>	$f_0 = f_1 / f_2$	FP divide (double precision)
Comparison	FP square root double	<code>fsqrt.d f0, f1</code>	$f_0 = \sqrt{f_1}$	FP square root (double precision)
	FP equality single	<code>feq.s x5, f0, f1</code>	$x_5 = 1$ if $f_0 == f_1$, else 0	FP comparison (single precision)
	FP less than single	<code>flt.s x5, f0, f1</code>	$x_5 = 1$ if $f_0 < f_1$, else 0	FP comparison (single precision)
	FP less than or equals single	<code>fle.s x5, f0, f1</code>	$x_5 = 1$ if $f_0 \leq f_1$, else 0	FP comparison (single precision)
	FP equality double	<code>feq.d x5, f0, f1</code>	$x_5 = 1$ if $f_0 == f_1$, else 0	FP comparison (double precision)
	FP less than double	<code>flt.d x5, f0, f1</code>	$x_5 = 1$ if $f_0 < f_1$, else 0	FP comparison (double precision)
Data transfer	FP less than or equals double	<code>fle.d x5, f0, f1</code>	$x_5 = 1$ if $f_0 \leq f_1$, else 0	FP comparison (double precision)
	FP load word	<code>flw f0, 4(x5)</code>	$f_0 = \text{Memory}[x_5 + 4]$	Load single-precision from memory
	FP load doubleword	<code>fld f0, 8(x5)</code>	$f_0 = \text{Memory}[x_5 + 8]$	Load double-precision from memory
	FP store word	<code>fsw f0, 4(x5)</code>	$\text{Memory}[x_5 + 4] = f_0$	Store single-precision from memory
FP store doubleword	<code>fsd f0, 8(x5)</code>	$\text{Memory}[x_5 + 8] = f_0$	Store double-precision from memory	

FIGURE 3.17 RISC-V floating-point architecture revealed thus far.

This information is also found in column 2 of the RISC-V Reference Data Card at the front of this book.

Hardware/Software Interface

One issue that architects face in supporting floating-point arithmetic is whether to select the same registers used by the

integer instructions or to add a special set for floating point. Because programs normally perform integer operations and floating-point operations on different data, separating the registers will only slightly increase the number of instructions needed to execute a program. The major impact is to create a distinct set of data transfer instructions to move data between floating-point registers and memory.

The benefits of separate floating-point registers are having twice as many registers without using up more bits in the instruction format, having twice the register bandwidth by having separate integer and floating-point register sets, and being able to customize registers to floating point; for example, some computers convert all sized operands in registers into a single internal format.

Compiling a Floating-Point C Program into RISC-V Assembly Code

Example

Let's convert a temperature in Fahrenheit to Celsius:

```
float f2c (float fahr)
{
    return ((5.0f/9.0f) *(fahr - 32.0f));
}
```

Assume that the floating-point argument `fahr` is passed in `f10` and the result should also go in `f10`. What is the RISC-V assembly code?

Answer

We assume that the compiler places the three floating-point constants in memory within easy reach of register `x3`. The first two instructions load the constants 5.0 and 9.0 into floating-point registers:

```
f2c:
    flw f0, const5(x3) // f0 = 5.0f
    flw f1, const9(x3) // f1 = 9.0f
```

They are then divided to get the fraction 5.0/9.0:

```
fdiv.s f0, f0, f1 // f0 = 5.0f / 9.0f
```

(Many compilers would divide 5.0 by 9.0 at compile time and save the single constant 5.0/9.0 in memory, thereby avoiding the

divide at runtime.) Next, we load the constant 32.0 and then subtract it from `fahr` (`f10`):

```
flw f1, const32(x3) // f1 = 32.0f
fsub.s f10, f10, f1 // f10 = fahr - 32.0f
```

Finally, we multiply the two intermediate results, placing the product in `f10` as the return result, and then return

```
fmul.s f10, f0, f10 // f10 = (5.0f / 9.0f)*(fahr - 32.0f)
jalr x0, 0(x1) // return
```

Now let's perform floating-point operations on matrices, code commonly found in scientific programs.

Compiling Floating-Point C Procedure with Two-Dimensional Matrices into RISC-V

Example

Most floating-point calculations are performed in double precision. Let's perform matrix multiply of $C = C + A * B$. It is commonly called *DGEMM*, for Double precision, General Matrix Multiply. We'll see versions of *DGEMM* again in [Section 3.8](#) and subsequently in [Chapters 4, 5, and 6](#). Let's assume *C*, *A*, and *B* are all square matrices with 32 elements in each dimension.

```
void mm (double c[][], double a[][], double b[][])
{
    size_t i, j, k;
    for (i = 0; i < 32; i = i + 1)
        for (j = 0; j < 32; j = j + 1)
            for (k = 0; k < 32; k = k + 1)
                c[i][j] = c[i][j] + a[i][k] * b[k][j];
}
```

The array starting addresses are parameters, so they are in `x10`, `x11`, and `x12`. Assume that the integer variables are in `x5`, `x6`, and `x7`, respectively. What is the RISC-V assembly code for the body of the procedure?

Answer

Note that `c[i][j]` is used in the innermost loop above. Since the loop index is `k`, the index does not affect `c[i][j]`, so we can avoid loading and storing `c[i][j]` each iteration. Instead, the compiler loads `c[i][j]` into a register outside the loop, accumulates the sum

of the products of $a[i][k]$ and $b[k][j]$ in that same register, and then stores the sum into $c[i][j]$ upon termination of the innermost loop. We keep the code simpler by using the assembly language pseudoinstruction `li`, which loads a constant into a register.

The body of the procedure starts with saving the loop termination value of 32 in a temporary register and then initializing the three *for* loop variables:

```
mm:...
    li x28, 32 // x28 = 32 (row size/loop end)
    li x5, 0 // i = 0; initialize 1st for loop
L1: li x6, 0 // j = 0; initialize 2nd for loop
L2: li x7, 0 // k = 0; initialize 3rd for loop
```

To calculate the address of $c[i][j]$, we need to know how a 32×32 , two-dimensional array is stored in memory. As you might expect, its layout is the same as if there were 32 single-dimensional arrays, each with 32 elements. So the first step is to skip over the i “single-dimensional arrays,” or rows, to get the one we want. Thus, we multiply the index in the first dimension by the size of the row, 32. Since 32 is a power of 2, we can use a shift instead:

```
slli x30, x5, 5 // x30 = i * 25(size of row of c)
```

Now we add the second index to select the j th element of the desired row:

```
add x30, x30, x6 // x30 = i * size(row) + j
```

To turn this sum into a byte index, we multiply it by the size of a matrix element in bytes. Since each element is 8 bytes for double precision, we can instead shift left by three:

```
slli x30, x30, 3 // x30 = byte offset of [i][j]
```

Next we add this sum to the base address of c , giving the address of $c[i][j]$, and then load the double precision number $c[i][j]$ into $f0$:

```
add x30, x10, x30 // x30 = byte address of c[i][j]
fld f0, 0(x30) // f0 = 8 bytes of c[i][j]
```

The following five instructions are virtually identical to the last five: calculate the address and then load the double precision number $b[k][j]$.

```
L3: slli x29, x7, 5 // x29 = k * 25(size of row of b)
    add x29, x29, x6 // x29 = k * size(row) + j
    slli x29, x29, 3 // x29 = byte offset of [k][j]
```

```

add x29, x12, x29 // x29 = byte address of b[k][j]
fld f1, 0(x29) // f1 = 8 bytes of b[k][j]

```

Similarly, the next five instructions are like the last five: calculate the address and then load the double precision number $a[i][k]$.

```

slli x29, x5, 5 // x29 =  $i * 2^5$  (size of row of a)
add x29, x29, x7 // x29 =  $i * \text{size}(\text{row}) + k$ 
slli x29, x29, 3 // x29 = byte offset of [i][k]
add x29, x11, x29 // x29 = byte address of a[i][k]
fld f2, 0(x29) // f2 = a[i][k]

```

Now that we have loaded all the data, we are finally ready to do some floating-point operations! We multiply elements of a and b located in registers $f2$ and $f1$, and then accumulate the sum in $f0$.

```

fmul.d f1, f2, f1 // f1 =  $a[i][k] * b[k][j]$ 
fadd.d f0, f0, f1 //  $f0 = c[i][j] + a[i][k] * b[k][j]$ 

```

The final block increments the index k and loops back if the index is not 32. If it is 32, and thus the end of the innermost loop, we need to store the sum accumulated in $f0$ into $c[i][j]$.

```

addi x7, x7, 1 //  $k = k + 1$ 
bltu x7, x28, L3 // if ( $k < 32$ ) go to L3
fsd f0, 0(x30) //  $c[i][j] = f0$ 

```

Similarly, these final six instructions increment the index variable of the middle and outermost loops, looping back if the index is not 32 and exiting if the index is 32.

```

addi x6, x6, 1 //  $j = j + 1$ 
bltu x6, x28, L2 // if ( $j < 32$ ) go to L2
addi x5, x5, 1 //  $i = i + 1$ 
bltu x5, x28, L1 // if ( $i < 32$ ) go to L1
. . .

```

Looking ahead, [Figure 3.20](#) below shows the x86 assembly language code for a slightly different version of DGEMM in [Figure 3.19](#).

Elaboration

C and many other programming languages use the array layout discussed in the example, called *row-major order*. Fortran instead uses *column-major order*, whereby the array is stored column by column.

Elaboration

Another reason for separate integers and floating-point registers is that microprocessors in the 1980s didn't have enough transistors to put the floating-point unit on the same chip as the integer unit. Hence, the floating-point unit, including the floating-point registers, was optionally available as a second chip. Such optional accelerator chips are called *coprocessor chips*. Since the early 1990s, microprocessors have integrated floating point (and just about everything else) on chip, and thus the term *coprocessor chip* joins *accumulator* and *core memory* as quaint terms that date the speaker.

Elaboration

As mentioned in [Section 3.4](#), accelerating division is more challenging than multiplication. In addition to SRT, another technique to leverage a fast multiplier is *Newton's iteration*, where division is recast as finding the zero of a function to produce the reciprocal $1/c$, which is then multiplied by the other operand. Iteration techniques *cannot* be rounded properly without calculating many extra bits. A TI chip solved this problem by calculating an extra-precise reciprocal.

Elaboration

Java embraces IEEE 754 by name in its definition of Java floating-point data types and operations. Thus, the code in the first example could have well been generated for a class method that converted Fahrenheit to Celsius.

The second example above uses multiple dimensional arrays, which are not explicitly supported in Java. Java allows arrays of arrays, but each array may have its own length, unlike multiple dimensional arrays in C. Like the examples in [Chapter 2](#), a Java version of this second example would require a good deal of checking code for array bounds, including a new length calculation at the end of row accesses. It would also need to check that the object reference is not null.

Accurate Arithmetic

Unlike integers, which can represent exactly every number between the smallest and largest number, floating-point numbers are

normally approximations for a number they can't really represent. The reason is that an infinite variety of real numbers exists between, say, 1 and 2, but no more than 2^{53} can be represented exactly in double precision floating point. The best we can do is getting the floating-point representation close to the actual number. Thus, IEEE 754 offers several modes of rounding to let the programmer pick the desired approximation.

Rounding sounds simple enough, but to round accurately requires the hardware to include extra bits in the calculation. In the preceding examples, we were vague on the number of bits that an intermediate representation can occupy, but clearly, if every intermediate result had to be truncated to the exact number of digits, there would be no opportunity to round. IEEE 754, therefore, always keeps two extra bits on the right during intervening additions, called **guard** and **round**, respectively. Let's do a decimal example to illustrate their value.

guard

The first of two extra bits kept on the right during intermediate calculations of floating-point numbers; used to improve rounding accuracy.

round

Method to make the intermediate floating-point result fit the floating-point format; the goal is typically to find the nearest number that can be represented in the format. It is also the name of the second of two extra bits kept on the right during intermediate floating-point calculations, which improves rounding accuracy.

Rounding with Guard Digits

Example

Add $2.56_{\text{ten}} \times 10^0$ to $2.34_{\text{ten}} \times 10^2$, assuming that we have three significant decimal digits. Round to the nearest decimal number with three significant decimal digits, first with guard and round digits, and then without them.

Answer

First we must shift the smaller number to the right to align the exponents, so $2.56_{\text{ten}} \times 10^0$ becomes $0.0256_{\text{ten}} \times 10^2$. Since we have guard and round digits, we are able to represent the two least significant digits when we align exponents. The guard digit holds 5 and the round digit holds 6. The sum is

$$\begin{array}{r} 2.3400_{\text{ten}} \\ +0.0256_{\text{ten}} \\ \hline 2.3656_{\text{ten}} \end{array}$$

Thus the sum is $2.3656_{\text{ten}} \times 10^2$. Since we have two digits to round, we want values 0 to 49 to round down and 51 to 99 to round up, with 50 being the tiebreaker. Rounding the sum up with three significant digits yields $2.37_{\text{ten}} \times 10^2$.

Doing this *without* guard and round digits drops two digits from the calculation. The new sum is then

$$\begin{array}{r} 2.34_{\text{ten}} \\ +0.02_{\text{ten}} \\ \hline 2.36_{\text{ten}} \end{array}$$

The answer is $2.36_{\text{ten}} \times 10^2$, off by 1 in the last digit from the sum above.

Since the worst case for rounding would be when the actual number is halfway between two floating-point representations, accuracy in floating point is normally measured in terms of the number of bits in error in the least significant bits of the significand; the measure is called the number of **units in the last place**, or **ulp**. If a number were off by 2 in the least significant bits, it would be called off by 2 ulps. Provided there are no overflow, underflow, or invalid operation exceptions, IEEE 754 guarantees that the computer uses the number that is within one-half ulp.

units in the last place (ulp)

The number of bits in error in the least significant bits of the

significand between the actual number and the number that can be represented.

Elaboration

Although the example above really needed just one extra digit, multiply can require two. A binary product may have one leading 0 bit; hence, the normalizing step must shift the product one bit left. This shifts the guard digit into the least significant bit of the product, leaving the round bit to help accurately round the product.

IEEE 754 has four rounding modes: always round up (toward $+\infty$), always round down (toward $-\infty$), truncate, and round to nearest even. The final mode determines what to do if the number is exactly halfway in between. The U.S. *Internal Revenue Service* (IRS) always rounds 0.50 dollars up, possibly to the benefit of the IRS. A more equitable way would be to round up this case half the time and round down the other half. IEEE 754 says that if the least significant bit retained in a halfway case would be odd, add one; if it's even, truncate. This method always creates a 0 in the least significant bit in the tie-breaking case, giving the rounding mode its name. This mode is the most commonly used, and the only one that Java supports.

The goal of the extra rounding bits is to allow the computer to get the same results as if the intermediate results were calculated to infinite precision and then rounded. To support this goal and round to the nearest even, the standard has a third bit in addition to guard and round; it is set whenever there are nonzero bits to the right of the round bit. This **sticky bit** allows the computer to see the difference between $0.50 \dots 00_{\text{ten}}$ and $0.50 \dots 01_{\text{ten}}$ when rounding.

sticky bit

A bit used in rounding in addition to guard and round that is set whenever there are nonzero bits to the right of the round bit.

The sticky bit may be set, for example, during addition, when the smaller number is shifted to the right. Suppose we added $5.01_{\text{ten}} \times$

10^{-1} to $2.34_{\text{ten}} \times 10^2$ in the example above. Even with guard and round, we would be adding 0.0050 to 2.34, with a sum of 2.3450. The sticky bit would be set, since there are nonzero bits to the right. Without the sticky bit to remember whether any 1s were shifted off, we would assume the number is equal to 2.345000 ... 00 and round to the nearest even of 2.34. With the sticky bit to remember that the number is larger than 2.345000 ... 00, we round instead to 2.35.

Elaboration

RISC-V, MIPS-64, PowerPC, SPARC64, AMD SSE5, and Intel AVX architectures all provide a single instruction that does a multiply and add on three registers: $a=a+(b \times c)$. Obviously, this instruction allows potentially higher floating-point performance for this common operation. Equally important is that instead of performing two roundings—after the multiply and then after the add—which would happen with separate instructions, the multiply add instruction can perform a single rounding after the add. A single rounding step increases the precision of multiply add. Such operations with a single rounding are called **fused multiply add**. It was added to the revised IEEE 754-2008 standard (see  [Section 3.11](#)).

fused multiply add

A floating-point instruction that performs both a multiply and an add, but rounds only once after the add.

Summary

The *Big Picture* that follows reinforces the stored-program concept from [Chapter 2](#); the meaning of the information cannot be determined just by looking at the bits, for the same bits can represent a variety of objects. This section shows that computer arithmetic is finite and thus can disagree with natural arithmetic. For example, the IEEE 754 standard floating-point representation

$$(-1)^5 \times (1 + \text{Fraction}) \times 2^{(\text{Exponent} - \text{Bias})}$$

is almost always an approximation of the real number. Computer systems must take care to minimize this gap between computer arithmetic and arithmetic in the real world, and programmers at times need to be aware of the implications of this approximation.

The BIG Picture

Bit patterns have no inherent meaning. They may represent signed integers, unsigned integers, floating-point numbers, instructions, character strings, and so on. What is represented depends on the instruction that operates on the bits in the word.

The major difference between computer numbers and numbers in the real world is that computer numbers have limited size and hence limited precision; it's possible to calculate a number too big or too small to be represented in a computer word. Programmers must remember these limits and write programs accordingly.

C type	Java type	Data transfers	Operations
long long int	long	ld, sd	add, sub, addi, mul, mulh, mulhu, mulhsu, div, divu, rem, remu, and, andi, or, ori, xor, xori
unsigned long long int	-	ld, sd	add, sub, addi, mul, mulh, mulhu, mulhsu, div, divu, rem, remu, and, andi, or, ori, xor, xori
char	-	lb, sb	add, sub, addi, mul, div, divu, rem, remu, and, andi, or, ori, xor, xori
short	char	lh, sh	add, sub, addi, mul, div, divu, rem, remu, and, andi, or, ori, xor, xori
float	float	flw, fsw	fadd.s, fsub.s, fmul.s, fdiv.s, feq.s,flt.s, fle.s
double	double	fld, fsd	fadd.d, fsub.d, fmul.d, fdiv.d, feq.d,flt.d, fle.d

Hardware/ Software Interface

In the last chapter, we presented the storage classes of the programming language C (see the *Hardware/Software Interface* section in [Section 2.7](#)). The table above shows some of the C and Java data types, the data transfer instructions, and instructions that operate on those types that appear in [Chapter 2](#) and this chapter. Note that Java omits unsigned integers.

Check Yourself

The revised IEEE 754-2008 standard added a 16-bit floating-point format with five exponent bits. What do you think is the likely range of numbers it could represent?

1. $1.0000\ 00 \times 2^0$ to $1.1111\ 1111\ 11 \times 2^{31}$, 0
2. $\pm 1.0000\ 0000\ 0 \times 2^{-14}$ to $\pm 1.1111\ 1111\ 1 \times 2^{15}$, ± 0 , $\pm\infty$, NaN

3. $\pm 1.0000\ 0000\ 00 \times 2^{-14}$ to $\pm 1.1111\ 1111\ 11 \times 2^{15}$, ± 0 , $\pm\infty$, NaN
4. $\pm 1.0000\ 0000\ 00 \times 2^{-15}$ to $\pm 1.1111\ 1111\ 11 \times 2^{14}$, ± 0 , $\pm\infty$, NaN

Elaboration

To accommodate comparisons that may include NaNs, the standard includes *ordered* and *unordered* as options for compares. RISC-V does not provide instructions for unordered comparisons, but a careful sequence of ordered comparisons has the same effect. (Java does not support unordered compares.)

In an attempt to squeeze every bit of precision from a floating-point operation, the standard allows some numbers to be represented in unnormalized form. Rather than having a gap between 0 and the smallest normalized number, IEEE allows *denormalized numbers* (also known as *denorms* or *subnormals*). They have the same exponent as zero but a nonzero fraction. They allow a number to degrade in significance until it becomes 0, called *gradual underflow*. For example, the smallest positive single precision normalized number is

$$1.00000000\ 0000\ 0000\ 0000\ 0000_{\text{two}} \times 2^{-126}$$

but the smallest single precision denormalized number is

$$0.00000000\ 0000\ 0000\ 0000\ 0001_{\text{two}} \times 2^{-126}, \text{ or } 1.0_{\text{two}} \times 2^{-149}$$

For double precision, the denorm gap goes from 1.0×2^{-1022} to 1.0×2^{-1074} .

The possibility of an occasional unnormalized operand has given headaches to floating-point designers who are trying to build fast floating-point units. Hence, many computers cause an exception if an operand is denormalized, letting software complete the operation. Although software implementations are perfectly valid, their lower performance has lessened the popularity of denorms in portable floating-point software. Moreover, if programmers do not expect denorms, their programs may surprise them.

3.6 Parallelism and Computer Arithmetic: Subword Parallelism

Since every microprocessor in a phone, tablet, or laptop by definition has its own graphical display, as transistor budgets increased it was inevitable that support would be added for graphics operations.

Many graphics systems originally used 8 bits to represent each of the three primary colors plus 8 bits for a location of a pixel. The addition of speakers and microphones for teleconferencing and video games suggested support of sound as well. Audio samples need more than 8 bits of precision, but 16 bits are sufficient.

Every microprocessor has special support so that bytes and halfwords take up less space when stored in memory (see [Section 2.9](#)), but due to the infrequency of arithmetic operations on these data sizes in typical integer programs, there was little support beyond data transfers. Architects recognized that many graphics and audio applications would perform the same operation on vectors of these data. By partitioning the carry chains within a 128-bit adder, a processor could use **parallelism** to perform simultaneous operations on short vectors of sixteen 8-bit operands, eight 16-bit operands, four 32-bit operands, or two 64-bit operands.



PARALLELISM

The cost of such partitioned adders was small yet the speedups could be large.

Given that the parallelism occurs within a wide word, the extensions are classified as *subword parallelism*. It is also classified under the more general name of *data level parallelism*. They are known as well as vector or SIMD, for single instruction, multiple data (see [Section 6.6](#)). The rising popularity of multimedia applications led to arithmetic instructions that support narrower operations that can easily compute in parallel. As of this writing, RISC-V does not have additional instructions to exploit subword parallelism, but the next section presents a real-world example of such an architecture.

3.7 Real Stuff: Streaming SIMD Extensions and Advanced Vector Extensions in x86

The original MMX (*MultiMedia eXtension*) for the x86 included instructions that operate on short vectors of integers. Later, SSE (*Streaming SIMD Extension*) provided instructions that operate on short vectors of single-precision floating-point numbers. [Chapter 2](#) notes that in 2001 Intel added 144 instructions to its architecture as part of SSE2, including double precision floating-point registers and operations. It included eight 64-bit registers that can be used for floating-point operands. AMD expanded the number to 16 registers, called XMM, as part of AMD64, which Intel relabeled EM64T for its use. [Figure 3.18](#) summarizes the SSE and SSE2 instructions.

Data transfer	Arithmetic	Compare
MOV[AU]{SS PS SD PD} xmm, {mem xmm}	ADD{SS PS SD PD} xmm, {mem xmm}	CMP{SS PS SD PD}
	SUB{SS PS SD PD} xmm, {mem xmm}	
MOV[HL]{PS PD} xmm, {mem xmm}	MUL{SS PS SD PD} xmm, {mem xmm}	
	DIV{SS PS SD PD} xmm, {mem xmm}	
	SQRT{SS PS SD PD} {mem xmm}	
	MAX{SS PS SD PD} {mem xmm}	
	MIN{SS PS SD PD} {mem xmm}	

FIGURE 3.18 The SSE/SSE2 floating-point instructions of the x86.

xmm means one operand is a 128-bit SSE2 register, and {mem|xmm} means the other operand is either in memory or it is an SSE2 register. The table uses regular expressions to show the variations of instructions. Thus, MOV[AU]{SS|PS|SD|PD} represents the eight instructions

MOVASS, MOVAPS, MOVASD, MOVAPD, MOVUSS, MOVUPS, MOVUSD,

and MOVUPD. We use square brackets [] to show single-letter alternatives: A means the 128-bit operand is aligned in memory; U means the 128-bit operand is unaligned in memory; H means move the high half of the 128-bit operand; and L means move the low half of the 128-bit operand. We use the curly brackets {} with a vertical bar | to show multiple letter variations of the basic operations: SS stands for *Scalar Single* precision floating point, or one 32-bit operand in a 128-bit register; PS stands for *Packed Single* precision floating point, or four 32-bit operands in a 128-bit register; SD stands for *Scalar Double* precision floating point, or one 64-bit operand in a 128-bit register; PD stands for *Packed Double* precision floating point, or two 64-bit operands in a 128-bit register.

In addition to holding a single precision or double precision number in a register, Intel allows multiple floating-point operands to be packed into a single 128-bit SSE2 register: four single precision or two double precision. Thus, the 16 floating-point registers for SSE2 are actually 128 bits wide. If the operands can be arranged in memory as 128-bit aligned data, then 128-bit data transfers can load and store multiple operands per instruction. This packed floating-point format is supported by arithmetic operations that can

compute simultaneously on four singles (PS) or two doubles (PD).

In 2011, Intel doubled the width of the registers again, now called YMM, with *Advanced Vector Extensions* (AVX). Thus, a single operation can now specify eight 32-bit floating-point operations or four 64-bit floating-point operations. The legacy SSE and SSE2 instructions now operate on the lower 128 bits of the YMM registers. Thus, to go from 128-bit and 256-bit operations, you prepend the letter “v” (for vector) in front of the SSE2 assembly language operations and then use the YMM register names instead of the XMM register name. For example, the SSE2 instruction to perform two 64-bit floating-point additions

```
addpd %xmm0, %xmm4
```

becomes

```
vaddpd %ymm0, %ymm4
```

which now produces four 64-bit floating-point multiplies. Intel has announced plans to widen the AVX registers to first 512 bits and later 1024 bits in later editions of the x86 architecture.

Elaboration

AVX also added three address instructions to x86. For example, `vaddpd` can now specify

```
vaddpd %ymm0, %ymm1, %ymm4 // %ymm4 = %ymm0 + %ymm1
```

instead of the standard, two address version

```
addpd %xmm0, %xmm4 // %xmm4 = %xmm4 + %xmm0
```

(Unlike RISC-V, the destination is on the right in x86.) Three addresses can reduce the number of registers and instructions needed for a computation.

3.8 Going Faster: Subword Parallelism and Matrix Multiply

To demonstrate the performance impact of subword parallelism, we’ll run the same code on the Intel Core i7 first without AVX and then with it. [Figure 3.19](#) shows an unoptimized version of a matrix-matrix multiply written in C. As we saw in [Section 3.5](#), this program is commonly called *DGEMM*, which stands for Double precision GEneral Matrix Multiply. Starting with this edition, we have added a new section entitled “Going Faster” to demonstrate

the performance benefit of adapting software to the underlying hardware, in this case the Sandy Bridge version of the Intel Core i7 microprocessor. This new section in Chapters 3, 4, 5, and 6 will incrementally improve DGEMM performance using the ideas that each chapter introduces.

```
1. void dgemm (size_t n, double* A, double* B, double* C)
2. {
3.   for (size_t i = 0; i < n; ++i)
4.     for (size_t j = 0; j < n; ++j)
5.       {
6.         double cij = C[i+j*n]; /* cij = C[i][j] */
7.         for(size_t k = 0; k < n; k++ )
8.           cij += A[i+k*n] * B[k+j*n]; /*cij+=A[i][k]*B[k][j]*/
9.         C[i+j*n] = cij; /* C[i][j] = cij */
10.      }
11. }
```

FIGURE 3.19 Unoptimized C version of a double precision matrix multiply, widely known as DGEMM for Double-precision General Matrix Multiply.

Because we are passing the matrix dimension as the parameter n , this version of DGEMM uses single-dimensional versions of matrices C , A , and B and address arithmetic to get better performance instead of using the more intuitive two-dimensional arrays that we saw in [Section 3.5](#). The comments remind us of this more intuitive notation.

[Figure 3.20](#) shows the x86 assembly language output for the inner loop of [Figure 3.19](#). The five floating point-instructions start with a v like the AVX instructions, but note that they use the XMM registers instead of YMM, and they include sd in the name, which stands for scalar double precision. We'll define the subword parallel instructions shortly.

```

1. vmovsd (%r10),%xmm0           // Load 1 element of C into %xmm0
2. mov    %rsi,%rcx              // register %rcx = %rsi
3. xor    %eax,%eax              // register %eax = 0
4. vmovsd (%rcx),%xmm1           // Load 1 element of B into %xmm1
5. add    %r9,%rcx               // register %rcx = %rcx + %r9
6. vmulsd (%r8,%rax,8),%xmm1,%xmm1 // Multiply %xmm1,element of A
7. add    $0x1,%rax              // register %rax = %rax + 1
8. cmp    %eax,%edi              // compare %eax to %edi
9. vaddsd %xmm1,%xmm0,%xmm0      // Add %xmm1, %xmm0
10. jg    30 <dgemm+0x30>         // jump if %eax > %edi
11. add    $0x1,%r11              // register %r11 = %r11 + 1
12. vmovsd %xmm0,(%r10)          // Store %xmm0 into C element

```

FIGURE 3.20 The x86 assembly language for the body of the nested loops generated by compiling the unoptimized C code in [Figure 3.19](#).

Although it is dealing with just 64 bits of data, the compiler uses the AVX version of the instructions instead of SSE2 presumably so that it can use three address per instruction instead of two (see the *Elaboration* in [Section 3.7](#)).

While compiler writers may eventually be able to produce high-quality code routinely that uses the AVX instructions of the x86, for now we must “cheat” by using C intrinsics that more or less tell the compiler exactly how to produce good code. [Figure 3.21](#) shows the enhanced version of [Figure 3.19](#) for which the Gnu C compiler produces AVX code. [Figure 3.22](#) shows annotated x86 code that is the output of compiling using gcc with the `-O3` level of optimization.

```

1. //include <x86intrin.h>
2. void dgemm (size_t n, double* A, double* B, double* C)
3. {
4.     for ( size_t i = 0; i < n; i+=4 )
5.         for ( size_t j = 0; j < n; j++ ) {
6.             __m256d c0 = _mm256_load_pd(C+i+j*n); /* c0 = C[i][j] */
7.             for( size_t k = 0; k < n; k++ )
8.                 c0 = _mm256_add_pd(c0, /* c0 += A[i][k]*B[k][j] */
9.                     _mm256_mul_pd(_mm256_load_pd(A+i+k*n),
10.                    _mm256_broadcast_sd(B+k+j*n)));
11.             _mm256_store_pd(C+i+j*n, c0); /* C[i][j] = c0 */
12.         }
13. }

```

FIGURE 3.21 Optimized C version of DGEMM using C intrinsics to generate the AVX subword-parallel instructions for the x86.

Figure 3.22 shows the assembly language produced by the compiler for the inner loop.

```

1. vmovapd (%r11),%ymm0           // Load 4 elements of C into %ymm0
2. mov     %rbx,%rcx              // register %rcx = %rbx
3. xor     %eax,%eax              // register %eax = 0
4. vbroadcastsd (%rax,%r8,1),%ymm1 // Make 4 copies of B element
5. add     $0x8,%rax              // register %rax = %rax + 8
6. vmulpd (%rcx),%ymm1,%ymm1     // Parallel mul %ymm1,4 A elements
7. add     %r9,%rcx              // register %rcx = %rcx + %r9
8. cmp     %r10,%rax             // compare %r10 to %rax
9. vaddpd %ymm1,%ymm0,%ymm0     // Parallel add %ymm1, %ymm0
10. jne    50 <dgemm+0x50>        // jump if not %r10 != %rax
11. add     $0x1,%esi             // register % esi = % esi + 1
12. vmovapd %ymm0,(%r11)         // Store %ymm0 into 4 C elements

```

FIGURE 3.22 The x86 assembly language for the body of the nested loops generated by compiling the optimized C code in Figure 3.21.

Note the similarities to Figure 3.20, with the primary difference being that the five floating-point operations are now using YMM registers and using the pd versions of the instructions for packed double precision

instead of the `sd` version for scalar double precision.

The declaration on line 6 of [Figure 3.21](#) uses the `__m256d` data type, which tells the compiler the variable will hold four double-precision floating-point values. The intrinsic `_mm256_load_pd()` also on line 6 uses AVX instructions to load four double-precision floating-point numbers in parallel (`_pd`) from the matrix `c` into `c0`. The address calculation `c+i+j*n` on line 6 represents element `c[i+j*n]`. Symmetrically, the final step on line 11 uses the intrinsic `_mm256_store_pd()` to store four double-precision floating-point numbers from `c0` into the matrix `c`. As we're going through four elements each iteration, the outer *for* loop on line 4 increments `i` by 4 instead of by 1 as on line 3 of [Figure 3.19](#).

Inside the loops, on line 9 we first load four elements of `A` again using `_mm256_load_pd()`. To multiply these elements by one element of `B`, on line 10 we first use the intrinsic `_mm256_broadcast_sd()`, which makes four identical copies of the scalar double precision number—in this case an element of `B`—in one of the YMM registers. We then use `_mm256_mul_pd()` on line 9 to multiply the four double-precision results in parallel. Finally, `_mm256_add_pd()` on line 8 adds the four products to the four sums in `c0`.

[Figure 3.22](#) shows resulting x86 code for the body of the inner loops produced by the compiler. You can see the five AVX instructions—they all start with `v` and four of the five use `pd` for packed double precision—that correspond to the C intrinsics mentioned above. The code is very similar to that in [Figure 3.20](#) above: both use 12 instructions, the integer instructions are nearly identical (but different registers), and the floating-point instruction differences are generally just going from *scalar double* (`sd`) using XMM registers to *packed double* (`pd`) with YMM registers. The one exception is line 4 of [Figure 3.22](#). Every element of `A` must be multiplied by one element of `B`. One solution is to place four identical copies of the 64-bit `B` element side-by-side into the 256-bit YMM register, which is just what the instruction `vbroadcastsd` does.

For matrices of dimensions of 32 by 32, the unoptimized DGEMM in [Figure 3.19](#) runs at 1.7 GigaFLOPS (Floating point Operations Per Second) on one core of a 2.6 GHz Intel Core i7 (Sandy Bridge). The optimized code in [Figure 3.21](#) performs at 6.4 GigaFLOPS. The AVX version is 3.85 times as fast, which is very close to the factor of

4.0 increase that you might hope for from performing four times as many operations at a time by using **subword parallelism**.



Elaboration

As mentioned in the *Elaboration* in [Section 1.6](#), Intel offers Turbo mode that temporarily runs at a higher clock rate until the chip gets too hot. This Intel Core i7 (Sandy Bridge) can increase from 2.6 GHz to 3.3 GHz in Turbo mode. The results above are with Turbo mode turned off. If we turn it on, we improve all the results by the increase in the clock rate of $3.3/2.6 = 1.27$ to 2.1 GFLOPS for unoptimized DGEMM and 8.1 GFLOPS with AVX. Turbo mode works particularly well when using only a single core of an eight-core chip, as in this case, as it lets that single core use much more than its fair share of power since the other cores are idle.

3.9 Fallacies and Pitfalls

Thus mathematics may be defined as the subject in which we never know what we are talking about, nor whether what we are saying is true.

Arithmetic fallacies and pitfalls generally stem from the difference between the limited precision of computer arithmetic and the unlimited precision of natural arithmetic.

Fallacy: Just as a left shift instruction can replace an integer multiply by a power of 2, a right shift is the same as an integer division by a power of 2.

Recall that a binary number x , where x_i means the i th bit, represents the number

$$\dots + (x^3 \times 2^3) + (x^2 \times 2^2) + (x^1 \times 2^1) + (x^0 \times 2^0)$$

Shifting the bits of c right by n bits would seem to be the same as dividing by 2^n . And this *is* true for unsigned integers. The problem is with signed integers. For example, suppose we want to divide -5_{ten} by 4_{ten} ; the quotient should be -1_{ten} . The two's complement representation of -5_{ten} is

11111111 11111111 11111111 11111111 11111111 11111111 11111111 11111011_{two}

According to this fallacy, shifting right by two should divide by 4_{ten} (2^2):

00111111 11111111 11111111 11111111 11111111 11111111 11111111 11111110_{two}

With a 0 in the sign bit, this result is clearly wrong. The value created by the shift right is actually $4,611,686,018,427,387,902_{\text{ten}}$ instead of -1_{ten} .

A solution would be to have an arithmetic right shift that extends the sign bit instead of shifting in 0s. A 2-bit arithmetic shift right of -5_{ten} produces

11111111 11111111 11111111 11111111 11111111 11111111 11111111 11111110_{two}

The result is -2_{ten} instead of -1_{ten} ; close, but no cigar.

Pitfall: Floating-point addition is not associative.

Associativity holds for a sequence of two's complement integer additions, even if the computation overflows. Alas, because floating-point numbers are approximations of real numbers and because computer arithmetic has limited precision, it does not hold for floating-point numbers. Given the great range of numbers that can be represented in floating point, problems occur when adding two large numbers of opposite signs plus a small number. For example, let's see if $c+(a+b)=(c+a)+b$. Assume $c=-1.5_{\text{ten}} \times 10^{38}$, $a = 1.5_{\text{ten}} \times 10^{38}$, and $b = 1.0$, and that these are all single precision numbers.

$$\begin{aligned}c + (a + b) &= -1.5_{\text{ten}} \times 10^{38} + (1.5_{\text{ten}} \times 10^{38} + 1.0) \\ &= -1.5_{\text{ten}} \times 10^{38} + (1.5_{\text{ten}} \times 10^{38}) \\ &= 0.0 \\ c + (a + b) &= (-1.5_{\text{ten}} \times 10^{38} + 1.5_{\text{ten}} \times 10^{38}) + 1.0 \\ &= (0.0_{\text{ten}}) + 1.0 \\ &= 1.0\end{aligned}$$

Since floating-point numbers have limited precision and result in approximations of real results, $1.5_{\text{ten}} \times 10^{38}$ is so much larger than 1.0_{ten} that $1.5_{\text{ten}} \times 10^{38} + 1.0$ is still $1.5_{\text{ten}} \times 10^{38}$. That is why the sum of c , a , and b is 0.0 or 1.0, depending on the order of the floating-point additions, so $c+(a+b) \neq (c+a)+b$. Therefore, floating-point addition is *not* associative.

Fallacy: Parallel execution strategies that work for integer data types also work for floating-point data types.

Programs have typically been written first to run sequentially before being rewritten to run concurrently, so a natural question is, "Do the two versions get the same answer?" If the answer is no, you presume there is a bug in the parallel version that you need to track down.

This approach assumes that computer arithmetic does not affect the results when going from sequential to parallel. That is, if you

were to add a million numbers together, you would get the same results whether you used one processor or 1000 processors. This assumption holds for two's complement integers, since integer addition is associative. Alas, since floating-point addition is not associative, the assumption does not hold.

A more vexing version of this fallacy occurs on a parallel computer where the operating system scheduler may use a different number of processors depending on what other programs are running on a parallel computer. As the varying number of processors from each run would cause the floating-point sums to be calculated in different orders, getting slightly different answers each time despite running identical code with identical input may flummox unaware parallel programmers.

Given this quandary, programmers who write parallel code with floating-point numbers need to verify whether the results are credible, even if they don't give the exact same answer as the sequential code. The field that deals with such issues is called numerical analysis, which is the subject of textbooks in its own right. Such concerns are one reason for the popularity of numerical libraries such as LAPACK and ScaLAPACK, which have been validated in both their sequential and parallel forms.

Fallacy: Only theoretical mathematicians care about floating-point accuracy.

Newspaper headlines of November 1994 prove this statement is a fallacy (see [Figure 3.23](#)). The following is the inside story behind the headlines.



FIGURE 3.23 A sampling of newspaper and magazine articles from November 1994, including the *New York Times*, *San Jose Mercury News*, *San Francisco Chronicle*, and *Infoworld*.

The Pentium floating-point divide bug even made the “Top 10 List” of the *David Letterman Late Show* on television. Intel eventually took a \$300 million write-off to replace the buggy chips.

The Pentium uses a standard floating-point divide algorithm that generates multiple quotient bits per step, using the most significant bits of divisor and dividend to guess the next 2 bits of the quotient. The guess is taken from a lookup table containing -2, -1, 0, +1, or +2. The guess is multiplied by the divisor and subtracted from the remainder to generate a new remainder. Like nonrestoring division, if a previous guess gets too large a remainder, the partial remainder is adjusted in a subsequent pass.

Evidently, there were five elements of the table from the 80486 that Intel engineers thought could never be accessed, and they optimized the PLA to return 0 instead of 2 in these situations on the Pentium. Intel was wrong: while the first 11 bits were always correct, errors would show up occasionally in bits 12 to 52, or the 4th to 15th decimal digits.

A math professor at Lynchburg College in Virginia, Thomas Nicely, discovered the bug in September 1994. After calling Intel technical support and getting no official reaction, he posted his discovery on the Internet. This post led to a story in a trade magazine, which in turn caused Intel to issue a press release. It called the bug a glitch that would affect only theoretical mathematicians, with the average spreadsheet user seeing an error every 27,000 years. IBM Research soon counterclaimed that the average spreadsheet user would see an error every 24 days. Intel soon threw in the towel by making the following announcement on December 21:

We at Intel wish to sincerely apologize for our handling of the recently publicized Pentium processor flaw. The Intel Inside symbol means that your computer has a microprocessor second to none in quality and performance. Thousands of Intel employees work very hard to ensure that this is true. But no microprocessor is ever perfect. What Intel continues to believe is technically an extremely minor problem has taken on a life of its own. Although Intel firmly stands behind the quality of the current version of the Pentium processor, we recognize that many users have concerns. We want to resolve these concerns. Intel will exchange the current version of the Pentium processor for an updated version, in which this floating-point divide flaw is corrected, for any owner who requests it, free of charge anytime during the life of their computer.

Analysts estimate that this recall cost Intel \$500 million, and Intel engineers did not get a Christmas bonus that year.

This story brings up a few points for everyone to ponder. How much cheaper would it have been to fix the bug in July 1994? What was the cost to repair the damage to Intel's reputation? And what is the corporate responsibility in disclosing bugs in a product so widely used and relied upon as a microprocessor?

3.10 Concluding Remarks

Over the decades, computer arithmetic has become largely standardized, greatly enhancing the portability of programs. Two's

complement binary integer arithmetic is found in every computer sold today, and if it includes floating point support, it offers the IEEE 754 binary floating-point arithmetic.

Computer arithmetic is distinguished from paper-and-pencil arithmetic by the constraints of limited precision. This limit may result in invalid operations through calculating numbers larger or smaller than the predefined limits. Such anomalies, called “overflow” or “underflow,” may result in exceptions or interrupts, emergency events similar to unplanned subroutine calls. [Chapters 4 and 5](#) discuss exceptions in more detail.

Floating-point arithmetic has the added challenge of being an approximation of real numbers, and care needs to be taken to ensure that the computer number selected is the representation closest to the actual number. The challenges of imprecision and limited representation of floating point are part of the inspiration for the field of numerical analysis. The switch to **parallelism** will shine the searchlight on numerical analysis again, as solutions that were long considered safe on sequential computers must be reconsidered when trying to find the fastest algorithm for parallel computers that still achieves a correct result.



P A R A L L E L I S M

Data-level parallelism, specifically subword parallelism, offers a simple path to higher performance for programs that are intensive

in arithmetic operations for either integer or floating-point data. We showed that we could speed up matrix multiply nearly fourfold by using instructions that could execute four floating-point operations at a time.

With the explanation of computer arithmetic in this chapter comes a description of much more of the RISC-V instruction set.

[Figure 3.24](#) ranks the popularity of the twenty most common RISC-V instructions for the SPEC CPU2006 integer and floating-point benchmarks. As you can see, a relatively small number of instructions dominate these rankings. This observation has significant implications for the design of the processor, as we will see in [Chapter 4](#).

RISC-V Instruction	Name	Frequency	Cumulative
Add immediate	addi	14.36%	14.36%
Load doubleword	ld	8.27%	22.63%
Load fl. pt. double	fld	6.83%	29.46%
Add registers	add	6.23%	35.69%
Load word	lw	4.38%	40.07%
Store doubleword	sd	4.29%	44.36%
Branch if not equal	bne	4.14%	48.50%
Shift left immediate	slli	3.65%	52.15%
Fused mul-add double	fmadd.d	3.49%	55.64%
Branch if equal	beq	3.27%	58.91%
Add immediate word	addiw	2.86%	61.77%
Store fl. pt. double	fsd	2.24%	64.00%
Multiply fl. pt. double	fmul.d	2.02%	66.02%
Load upper immediate	lui	1.56%	67.59%
Store word	sw	1.52%	69.10%
Jump and link	jal	1.38%	70.49%
Branch if less than	blt	1.37%	71.86%
Add word	addw	1.34%	73.19%
Subtract fl. pt. double	fsub.d	1.28%	74.47%
Branch if greater/equal	bge	1.27%	75.75%

FIGURE 3.24 The frequency of the RISC-V instructions for the SPEC CPU2006 benchmarks.

The 20 most popular instructions, which collectively account for 76% of all instructions executed, are included in the table. Pseudoinstructions are converted into RISC-V before execution, and hence do not appear here, explaining in part the popularity of `addi`.

No matter what the instruction set or its size—RISC-V, MIPS, x86—never forget that bit patterns have no inherent meaning. The same bit pattern may represent a signed integer, unsigned integer, floating-point number, string, instruction, and so on. In stored-program computers, it is the operation on the bit pattern that determines its meaning.



Historical Perspective and Further Reading

Gresham's Law ("Bad money drives out Good") for computers would say, "The Fast drives out the Slow even if the Fast is wrong."

W. Kahan, 1992

This section surveys the history of the floating point going back to von Neumann, including the surprisingly controversial IEEE standards effort, plus the rationale for the 80-bit stack architecture for floating point in the x86. See the rest of  [Section 3.11](#) online.



Historical Perspective and Further Reading

Gresham's Law ("Bad money drives out Good") for computers would say, "The Fast drives out the Slow even if the Fast is wrong."

W. Kahan, 1992

This section surveys the history of the floating point going back to

von Neumann, including the surprisingly controversial IEEE standards effort, the rationale for the 80-bit stack architecture for floating point in the IA-32, and an update on the next round of the standard.

At first it may be hard to imagine a subject of less interest than the correctness of computer arithmetic or its accuracy, and harder still to understand why a subject so old and mathematical should be so contentious. Computer arithmetic is as old as computing itself, and some of the subject's earliest notions, like the economical reuse of registers during serial multiplication and division, still command respect today. Maurice Wilkes [1985] recalled a conversation about that notion during his visit to the United States in 1946, before the earliest stored-program computer had been built:

... a project under von Neumann was to be set up at the Institute of Advanced Studies in Princeton.... Goldstine explained to me the principal features of the design, including the device whereby the digits of the multiplier were put into the tail of the accumulator and shifted out as the least significant part of the product was shifted in. I expressed some admiration at the way registers and shifting circuits were arranged ... and Goldstine remarked that things of that nature came very easily to von Neumann.

There is no controversy here; it can hardly arise in the context of exact integer arithmetic, so long as there is general agreement on what integer the correct result should be. However, as soon as approximate arithmetic enters the picture, so does controversy, as if one person's "negligible" must be another's "everything."

The First Dispute

Floating-point arithmetic kindled disagreement before it was ever built. John von Neumann was aware of Konrad Zuse's proposal for a computer in Germany in 1939 that was never built, probably because the floating point made it appear too complicated to finish before the Germans expected World War II to end. Hence, von Neumann refused to include it in the computer he built at Princeton. In an influential report coauthored in 1946 with H. H. Goldstine and A. W. Burks, he gave the arguments for and against

floating point. In favor:

... to retain in a sum or product as many significant digits as possible and ... to free the human operator from the burden of estimating and inserting into a problem "scale factors" — multiplication constants which serve to keep numbers within the limits of the machine.

Floating point was excluded for several reasons:

There is, of course, no denying the fact that human time is consumed in arranging for the introduction of suitable scale factors. We only argue that the time consumed is a very small percentage of the total time we will spend in preparing an interesting problem for our machine. The first advantage of the floating point is, we feel, somewhat illusory. In order to have such a floating point, one must waste memory capacity which could otherwise be used for carrying more digits per word. It would therefore seem to us not at all clear whether the modest advantages of a floating binary point offset the loss of memory capacity and the increased complexity of the arithmetic and control circuits.

The argument seems to be that most bits devoted to exponent fields would be bits wasted. Experience has proven otherwise.

One software approach to accommodate reals without floating-point hardware was called *floating vectors*; the idea was to compute at runtime one scale factor for a whole array of numbers, choosing the scale factor so that the array's biggest number would barely fill its field. By 1951, James H. Wilkinson had used this scheme extensively for matrix computations. The problem proved to be that a program might encounter a very large value, and hence the scale factor must accommodate these rare sizeable numbers. The common numbers would thus have many leading 0s, since all numbers had to use a single scale factor. Accuracy was sacrificed, because the least significant bits had to be lost on the right to accommodate leading 0s. This wastage became obvious to practitioners on early computers that displayed all their memory bits as dots on cathode ray tubes (like TV screens) because the loss of precision was visible. Where floating point deserved to be used,

no practical alternative existed.

Thus, true floating-point hardware became popular because it was useful. By 1957, floating-point hardware was almost ubiquitous. A decimal floating-point unit was available for the IBM 650, and soon the IBM 704, 709, 7090, 7094 ... series would offer binary floating-point hardware for double as well as single precision.

As a result, everybody had floating point, but every implementation was different.

Diversity versus Portability

Since roundoff introduces some error into almost all floating-point operations, to complain about another bit of error seems picayune. So for 20 years, nobody complained much that those operations behaved a little differently on different computers. If software required clever tricks to circumvent those idiosyncrasies and finally deliver results correct in all but the last several bits, such tricks were deemed part of the programmer's art. For a long time, matrix computations mystified most people who had no notion of error analysis; perhaps this continues to be true. That may be why people are still surprised that numerically stable matrix computations depend upon the quality of arithmetic in so few places, far fewer than are generally supposed. Books by Wilkinson and widely used software packages like Linpack and Eispack sustained a false impression, widespread in the early 1970s, that a modicum of skill sufficed to produce *portable* numerical software.

"Portable" here means that the software is distributed as source code in some standard language to be compiled and executed on practically any commercially significant computer, and that it will then perform its task as well as any other program performs that task on that computer. Insofar as numerical software has often been thought to consist entirely of computer-independent mathematical formulas, its portability has commonly been taken for granted; the mistake in that presumption will become clear shortly.

Packages like Linpack and Eispack cost so much to develop—over a hundred dollars per line of Fortran delivered—that they could not have been developed without U.S. government subsidy; their portability was a precondition for that subsidy. But nobody

thought to distinguish how various components contributed to their cost. One component was algorithmic—devise an algorithm that deserves to work on at least one computer despite its roundoff and over-/underflow limitations. Another component was the software engineering effort required to achieve and confirm portability to the diverse computers commercially significant at the time; this component grew more onerous as ever more diverse floating-point arithmetics blossomed in the 1970s. And yet scarcely anybody realized how much that diversity inflated the cost of such software packages.

A Backward Step

Early evidence that somewhat different arithmetics could engender grossly different software development costs was presented in 1964. It happened at a meeting of SHARE, the IBM mainframe users' group, at which IBM announced System/360, the successor to the 7094 series. One of the speakers described the tricks he had been forced to devise to achieve a level of quality for the S/360 library that was not quite so high as he had previously achieved for the 7094.

Von Neumann could have foretold part of the trouble, had he still been alive. In 1948, he and Goldstine had published a lengthy error analysis so difficult and so pessimistic that hardly anybody paid attention to it. It did predict correctly, however, that computations with larger arrays of data would probably fall prey to roundoff more often. IBM S/360s had bigger memories than 7094s, so data arrays could grow larger, and they did. To make matters worse, the S/360s had narrower single precision words (32 bits versus 36) and used a cruder arithmetic (hexadecimal or base 16 versus binary or base 2) with consequently poorer worst-case precision (21 significant bits versus 27) than the old 7094s. Consequently, software that had almost always provided (barely) satisfactory accuracy on 7094s too often produced inaccurate results when run on S/360s. The quickest way to recover adequate accuracy was to replace old codes' single precision declarations with double precision before recompilation for the S/360. This practice exercised S/360 double precision far more than had been expected.

The early S/360's worst troubles were caused by lack of a guard

digit in double precision. This lack showed up in multiplication as a failure of identities like $1.0 * x = x$ because multiplying x by 1.0 dropped x 's last hexadecimal digit (4 bits). Similarly, if x and y were very close but had different exponents, subtraction dropped off the last digit of the smaller operand before computing $x - y$. This final aberration in double precision undermined a precious theorem that single precision then (and now) honored: If $1/2 \leq x/y \leq 2$, then no rounding error can occur when $x - y$ is computed; it must be computed exactly.

Innumerable computations had benefited from this minor theorem, most often unwittingly, for several decades before its first formal announcement and proof. We had been taking all this stuff for granted.

The identities and theorems about exact relationships that persisted, despite roundoff, with reasonable implementations of approximate arithmetic were not appreciated until they were lost. Previously, it had been thought that the things to matter were precision (how many significant digits were carried) and range (the spread between over-/underflow thresholds). Since the S/360's double precision had more precision and wider range than the 7094's, software was expected to continue to work at least as well as before. But it didn't.

Programmers who had matured into program managers were appalled at the cost of converting 7094 software to run on S/360s. A small subcommittee of SHARE proposed improvements to the S/360 floating point. This committee was surprised and grateful to get a fair part of what they asked for from IBM, including all-important guard digits. By 1968, these had been retrofitted to S/360s in the field at considerable expense; worse than that was customers' loss of faith in IBM's infallibility (a lesson learned by Intel 30 years later). IBM employees who can remember the incident still shudder.

The People Who Built the Bombs

Seymour Cray was associated for decades with the CDC and Cray computers that were, when he built them, the world's biggest and fastest. He always understood what his customers wanted most: *speed*. And he gave it to them even if, in so doing, he also gave them arithmetics more "interesting" than anyone else's. Among his

customers have been the great government laboratories like those at Livermore and Los Alamos, where nuclear weapons were designed. The challenges of “interesting” arithmetics were pretty tame to people who had to overcome Mother Nature’s challenges.

Perhaps all of us could learn to live with arithmetic idiosyncrasy if only one computer’s idiosyncrasies had to be endured. Instead, when accumulating different computers’ different anomalies, software dies the Death of a Thousand Cuts. Here is an example from Cray’s computers:

```
if (x == 0.0) y = 17.0 else y = z/x
```

Could this statement be stopped by a divide-by-zero error? On a CDC 6600 it could. The reason was a conflict between the 6600’s adder, where x was compared with 0.0, and the multiplier and divider. The adder’s comparison examined x ’s leading 13 bits, which sufficed to distinguish zero from normal nonzero floating-point numbers x . The multiplier and divider examined only 12 leading bits. Consequently, tiny numbers existed that were nonzero to the adder but zero to the multiplier and divider! To avoid disasters with these tiny numbers, programmers learned to replace statements like the one above with

```
if (1.0 * x == 0.0) y = 17.0 else y = z/x
```

But this statement is unsafe to use in would-be portable software because it malfunctions obscurely on other computers designed by Cray, the ones marketed by Cray Research, Inc. If x was so huge that $2.0 * x$ would overflow, then $1.0 * x$ might overflow too! Overflow happens because Cray computers check the product’s exponent before the product’s exponent has been normalized, just to save the delay of a single AND gate.

Rounding error anomalies that are far worse than the over-/underflow anomaly just discussed also affect Cray computers. The worst error came from the lack of a guard digit in add/subtract, an affliction of IBM S/360s. Further bad luck for software is occasioned by the way Cray economized his multiplier; about one-third of the bits that normal multiplier arrays generate have been left out of his multipliers, because they would contribute less than a unit to the last place of the final Cray-rounded product. Consequently, a Cray multiplier errs by almost a bit more than might have been expected. This error is compounded when division takes three multiplications to improve an approximate reciprocal of the divisor and then

multiply the numerator by it. Square root compounds a few more multiplication errors.

The fast way drove out the slow, even though the fast was occasionally slightly wrong.

Making the World Safe for Floating Point, or Vice Versa

William Kahan was an undergraduate at the University of Toronto in 1953 when he learned to program its Ferranti-Manchester Mark-I computer. Because he entered the field early, Kahan became acquainted with a wide range of devices and a large proportion of the personalities active in computing; the numbers of both were small at that time. He has performed computations on slide rules, desktop mechanical calculators, tabletop analog differential analyzers, and so on; he has used all but the earliest electronic computers and calculators mentioned in this book.

Kahan's desire to deliver reliable software led to an interest in error analysis that intensified during two years of postdoctoral study in England, where he became acquainted with Wilkinson. In 1960, he resumed teaching at Toronto, where an IBM 7090 had been acquired, and was granted free rein to tinker with its operating system, Fortran compiler, and runtime library. (He denies that he ever came near the 7090 hardware with a soldering iron but admits asking to do so.) One story from that time illuminates how misconceptions and numerical anomalies in computer systems can incur awesome hidden costs.

A graduate student in aeronautical engineering used the 7090 to simulate the wings he was designing for short takeoffs and landings. He knew such a wing would be difficult to control if its characteristics included an abrupt onset of stall, but he thought he could avoid that. His simulations were telling him otherwise. Just to be sure that roundoff was not interfering, he had repeated many of his calculations in double precision and gotten results much like those in single; his wings had stalled abruptly in both precisions. Disheartened, the student gave up.

Meanwhile Kahan replaced IBM's logarithm program (ALOG) with one of his own, which he hoped would provide better accuracy. While testing it, Kahan reran programs using the new

version of ALOG. The student's results changed significantly; Kahan approached him to find out what had happened.

The student was puzzled. Much as the student preferred the results produced with the new ALOG—they predicted a gradual stall—he knew they must be wrong because they disagreed with his double precision results. The discrepancy between single and double precision results disappeared a few days later when a new release of IBM's double precision arithmetic software for the 7090 arrived. (The 7090 had no double precision hardware.) He went on to write a thesis about it and to build the wings; they performed as predicted. But that is not the end of the story.

In 1963, the 7090 was replaced by a faster 7094 with double precision floating-point hardware but with otherwise practically the same instruction set as the 7090. Only in double precision and only when using the new hardware did the wing stall abruptly again. A lot of time was spent to find out why. The 7094 hardware turned out, like the superseded 7090 software and the subsequent early S/360s, to lack a guard bit in double precision. Like so many programmers on those computers and on Cray's, the student discovered a trick to compensate for the lack of a guard digit; he wrote the expression $(0.5 - x) + 0.5$ in place of $1.0 - x$. Nowadays we would blush if we had to explain why such a trick might be necessary, but it solved the student's problem.

Meanwhile the lure of California was working on Kahan and his family; they came to Berkeley and he to the University of California. An opportunity presented itself in 1974 when accuracy questions induced Hewlett-Packard's calculator designers to call in a consultant. The consultant was Kahan, and his work dramatically improved the accuracy of HP calculators, but that is another story. Fruitful collaboration with congenial coworkers, however, fortified him for the next and crucial opportunity.

It came in 1976, when John F. Palmer at Intel was empowered to specify the "best possible" floating-point arithmetic for all of Intel's product line, as **Moore's Law** made it now possible to create a whole floating-point unit on a single chip. The floating-point standard was originally started for the iAPX-432, but when it was late, Intel started the 8086 as a short-term emergency stand-in until the iAPX-432 was ready. The iAPX-432 never became popular, so the emergency stand-in became the standard-bearer for Intel. The

8087 floating-point coprocessor for the 8086 was contemplated. (A *coprocessor* is simply an additional chip that accelerates a portion of the work of a processor; in this case, it accelerated floating-point computation.)

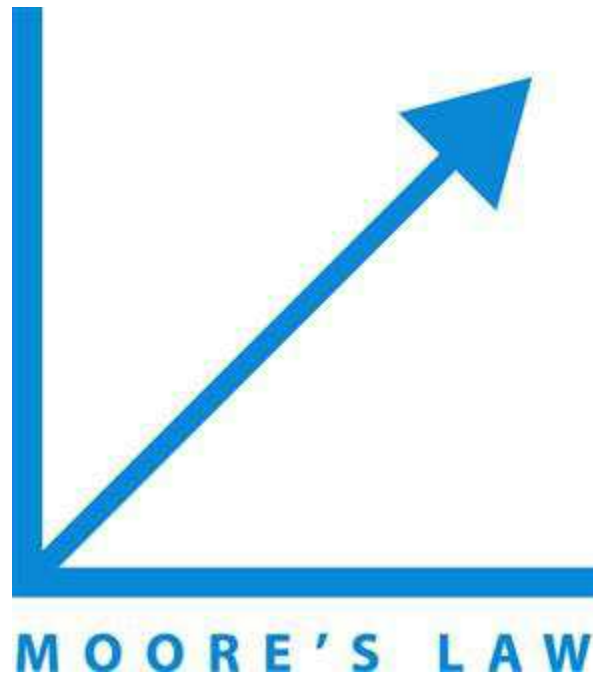

Palmer had obtained his Ph.D. at Stanford a few years before and knew whom to call for counsel of perfection—Kahan. They put together a design that obviously would have been impossible only a few years earlier and looked not quite possible at the time. But a new Israeli team of Intel employees led by Rafi Navé felt challenged to prove their prowess to Americans and leaped at an opportunity to put something impossible on a chip—the 8087.

By now, floating-point arithmetics that had been merely diverse among mainframes had become chaotic among microprocessors, one of which might be host to a dozen varieties of arithmetic in ROM firmware or software. Robert G. Stewart, an engineer prominent in IEEE activities, got fed up with this anarchy and proposed that the IEEE draft a decent floating-point standard. Simultaneously, word leaked out in Silicon Valley that Intel was going to put on one chip some awesome floating point well beyond anything its competitors had in mind. The competition had to find a way to slow Intel down, so they formed a committee to do what Stewart requested.

Meetings of this committee began in late 1977 with a plethora of competing drafts from innumerable sources and dragged on into 1985, when IEEE Standard 754 for Binary Floating Point was made official. The winning draft was very close to one submitted by Kahan, his student Jerome T. Coonen, and Harold S. Stone, a professor visiting Berkeley at the time. Their draft was based on the Intel design, with Intel's permission, of course, as simplified by Coonen. Their harmonious combination of features, almost none of them new, had at the outset attracted more support within the committee and from outside experts like Wilkinson than any other draft, but they had to win nearly unanimous support within the committee to win official IEEE endorsement, and that took time.

The First IEEE 754 Chips

In 1980, Intel became tired of waiting and released the 8087 for use in the IBM PC. The floating-point architecture of the companion 8087 had to be retrofitted into the 8086 opcode space, making it inconvenient to offer two operands per instruction as found in the rest of the 8086. Hence the decision for one operand per instruction using a stack: "The designer's task was to make a Virtue of this Necessity." (Kahan's [1990] history of the stack architecture selection for the 8087 is entertaining reading.)

Rather than the classical stack architecture, which has no provision for avoiding common subexpressions from being pushed and popped from memory into the top of the stack found in registers, Intel tried to combine a flat register file with a stack. The reasoning was that the restriction of the top of stack as one operand was not so bad since it only required the execution of an `FXCH` instruction (which swapped registers) to get the same result as a two-operand instruction, and `FXCH` was much faster than the floating-point operations of the 8087.

Since floating-point expressions are not that complex, Kahan reasoned that eight registers meant that the stack would rarely overflow. Hence, he urged that the 8087 use this hybrid scheme with the provision that stack overflow or stack underflow would interrupt the 8086 so that interrupt software could give the illusion to the compiler writer of an unlimited stack for floating-point data.

The Intel 8087 was implemented in Israel, and 7500 miles and 10

time zones made communication from California difficult. According to Palmer and Morse (*The 8087 Primer*, J. Wiley, New York, 1984, p. 93):

Unfortunately, nobody tried to write a software stack manager until after the 8087 was built, and by then it was too late; what was too complicated to perform in hardware turned out to be even worse in software. One thing found lacking is the ability to conveniently determine if an invalid operation is indeed due to a stack overflow.... Also lacking is the ability to restart the instruction that caused the stack overflow ...

The result is that the stack exceptions are too slow to handle in software. As Kahan [1990] says:

Consequently, almost all higher-level languages' compilers emit inefficient code for the 80x87 family, degrading the chip's performance by typically 50% with spurious stores and loads necessary simply to preclude stack over/under-flow....

I still regret that the 8087's stack implementation was not quite so neat as my original intention.... If the original design had been realized, compilers today would use the 80x87 and its descendents more efficiently, and Intel's competitors could more easily market faster but compatible 80x87 imitations.

In 1982, Motorola announced its 68881, which found a place in Sun 3s and Macintosh IIs; Apple had been a supporter of the proposal from the beginning. Another Berkeley graduate student, George S. Taylor, had soon designed a high-speed implementation of the proposed standard for an early superminicomputer (ELXSI 6400). The standard was becoming de facto before its final draft's ink was dry.

An early rush of adoptions gave the computing industry the false impression that IEEE 754, like so many other standards, could be implemented easily by following a standard recipe. Not true. Only the enthusiasm and ingenuity of its early implementors made it look easy.

In fact, to implement IEEE 754 correctly demands extraordinarily

diligent attention to detail; to make it run fast demands extraordinarily competent ingenuity of design. Had the industry's engineering managers realized this, they might not have been so quick to affirm that, as a matter of policy, "We conform to all applicable standards."

IEEE 754 Today

Unfortunately, the compiler-writing community was not represented adequately in the wrangling, and some of the features didn't balance language and compiler issues against other points. That community has been slow to make IEEE 754's unusual features available to the applications programmer. Humane exception handling is one such unusual feature; directed rounding another. Without compiler support, these features have atrophied.

The successful parts of IEEE 754 are that it is a widely implemented standard with a common floating-point format, that it requires minimum accuracy to one-half ulp in the least significant bit, and that operations must be commutative.

The IEEE 754/854 has been implemented to a considerable degree of fidelity in at least part of the product line of every North American computer manufacturer. The only significant exceptions were the DEC VAX, IBM S/370 descendants, and Cray Research vector supercomputers, and all three have been replaced by compliant computers.

IEEE rules ask that a standard be revisited periodically for updating. A committee started in 2000, and drafts of the revised standards were circulated for voting, and these were approved in 2008. The revised standard, IEEE Std 754-2008 [2008], includes several new types: 16-bit floating point, called *half precision*; 128-bit floating point, called *quad precision*; and three decimal types, matching the length of the 32-bit, 64-bit, and 128-bit binary formats. In 1989, the Association for Computing Machinery, acknowledging the benefits conferred upon the computing industry by IEEE 754, honored Kahan with the Turing Award. On accepting it, he thanked his many associates for their diligent support, and his adversaries for their blunders. So . . . not all errors are bad.

Further Reading

If you are interested in learning more about floating point, two publications by David Goldberg [1991, 2002] are good starting points; they abound with pointers to further reading. Several of the stories told in this section come from Kahan [1972, 1983]. The latest word on the state of the art in computer arithmetic is often found in the *Proceedings* of the most recent IEEE-sponsored Symposium on Computer Arithmetic, held every two years; the 23rd was held in 2016.

Burks, A.W., H.H. Goldstine, and J. von Neumann [1946]. "Preliminary discussion of the logical design of an electronic computing instrument," *Report to the U.S. Army Ordnance Dept.*, p. 1; also in *Papers of John von Neumann*, W. Aspray and A. Burks (Eds.), MIT Press, Cambridge, MA, and Tomash Publishers, Los Angeles, 1987, 97–146.

This classic paper includes arguments against floating-point hardware.

Goldberg, D. [2002]. "Computer arithmetic". [Appendix A](#) of *Computer Architecture: A Quantitative Approach*, third edition, J. L. Hennessy and D. A. Patterson, Morgan Kaufmann Publishers, San Francisco.

A more advanced introduction to integer and floating-point arithmetic, with emphasis on hardware. It covers [Sections 3.4–3.6](#) of this book in just 10 pages, leaving another 45 pages for advanced topics.

Goldberg, D. [1991]. "What every computer scientist should know about floating-point arithmetic", *ACM Computing Surveys* 23(1), 5–48.

Another good introduction to floating-point arithmetic by the same author, this time with emphasis on software.

Kahan, W. [1972]. "A survey of error-analysis," in *Info. Processing 71* (Proc. IFIP Congress 71 in Ljubljana), Vol. 2, North-Holland Publishing, Amsterdam, 1214–1239.

This survey is a source of stories on the importance of accurate arithmetic.

Kahan, W. [1983]. "Mathematics written in sand," *Proc. Amer. Stat. Assoc. Joint Summer Meetings of 1983, Statistical Computing Section*, 12–26.

The title refers to silicon and is another source of stories illustrating the importance of accurate arithmetic.

Kahan, W. [1990]. "On the advantage of the 8087's stack," unpublished course notes, Computer Science Division, University

of California, Berkeley.

What the 8087 floating-point architecture could have been.

Kahan, W. [1997]. Available at

<http://www.cims.nyu.edu/~dbindel/class/cs279/87stack.pdf>.

A collection of memos related to floating point, including “Beastly numbers” (another less famous Pentium bug), “Notes on the IEEE floating point arithmetic” (including comments on how some features are atrophying), and “The baleful effects of computing benchmarks” (on the unhealthy preoccupation on speed versus correctness, accuracy, ease of use, flexibility, ...).

Koren, I. [2002]. *Computer Arithmetic Algorithms*, second edition, A. K. Peters, Natick, MA.

A textbook aimed at seniors and first-year graduate students that explains fundamental principles of basic arithmetic, as well as complex operations such as logarithmic and trigonometric functions.

Wilkes, M. V. [1985]. *Memoirs of a Computer Pioneer*, MIT Press, Cambridge, MA.

This computer pioneer’s recollections include the derivation of the standard hardware for multiply and divide developed by von Neumann.

3.12 Exercises

Never give in, never give in, never, never, never — in nothing, great or small, large or petty — never give in.

Winston Churchill, address at Harrow School, 1941

- 3.1 [5] <§3.2>What is $5ED4 - 07A4$ when these values represent unsigned 16-bit hexadecimal numbers? The result should be written in hexadecimal. Show your work.
- 3.2 [5] <§3.2>What is $5ED4 - 07A4$ when these values represent signed 16-bit hexadecimal numbers stored in sign-magnitude format? The result should be written in hexadecimal. Show your work.
- 3.3 [10] <§3.2>Convert $5ED4$ into a binary number. What makes base 16 (hexadecimal) an attractive numbering system for representing values in computers?
- 3.4 [5] <§3.2>What is $4365 - 3412$ when these values represent unsigned 12-bit octal numbers? The result should be written in

octal. Show your work.

- 3.5 [5] <§3.2>What is $4365 - 3412$ when these values represent signed 12-bit octal numbers stored in sign-magnitude format? The result should be written in octal. Show your work.
- 3.6 [5] <§3.2>Assume 185 and 122 are unsigned 8-bit decimal integers. Calculate $185 - 122$. Is there overflow, underflow, or neither?
- 3.7 [5] <§3.2>Assume 185 and 122 are signed 8-bit decimal integers stored in sign-magnitude format. Calculate $185 + 122$. Is there overflow, underflow, or neither?
- 3.8 [5] <§3.2>Assume 185 and 122 are signed 8-bit decimal integers stored in sign-magnitude format. Calculate $185 - 122$. Is there overflow, underflow, or neither?
- 3.9 [10] <§3.2>Assume 151 and 214 are signed 8-bit decimal integers stored in two's complement format. Calculate $151 + 214$ using saturating arithmetic. The result should be written in decimal. Show your work.
- 3.10 [10] <§3.2>Assume 151 and 214 are signed 8-bit decimal integers stored in two's complement format. Calculate $151 - 214$ using saturating arithmetic. The result should be written in decimal. Show your work.
- 3.11 [10] <§3.2>Assume 151 and 214 are unsigned 8-bit integers. Calculate $151 + 214$ using saturating arithmetic. The result should be written in decimal. Show your work.
- 3.12 [20] <§3.3>Using a table similar to that shown in [Figure 3.6](#), calculate the product of the octal unsigned 6-bit integers 62 and 12 using the hardware described in [Figure 3.3](#). You should show the contents of each register on each step.
- 3.13 [20] <§3.3>Using a table similar to that shown in [Figure 3.6](#), calculate the product of the hexadecimal unsigned 8-bit integers 62 and 12 using the hardware described in [Figure 3.5](#). You should show the contents of each register on each step.
- 3.14 [10] <§3.3>Calculate the time necessary to perform a multiply using the approach given in [Figures 3.3](#) and [3.4](#) if an integer is 8 bits wide and each step of the operation takes four time units. Assume that in step 1a an addition is always performed—either the multiplicand will be added, or a zero will be. Also assume that the registers have already been initialized (you are just counting how long it takes to do the multiplication loop itself). If

this is being done in hardware, the shifts of the multiplicand and multiplier can be done simultaneously. If this is being done in software, they will have to be done one after the other. Solve for each case.

- 3.15 [10] <§3.3> Calculate the time necessary to perform a multiply using the approach described in the text (31 adders stacked vertically) if an integer is 8 bits wide and an adder takes four time units.
- 3.16 [20] <§3.3> Calculate the time necessary to perform a multiply using the approach given in [Figure 3.7](#) if an integer is 8 bits wide and an adder takes four time units.
- 3.17 [20] <§3.3> As discussed in the text, one possible performance enhancement is to do a shift and add instead of an actual multiplication. Since 9×6 , for example, can be written $(2 \times 2 \times 2 + 1) \times 6$, we can calculate 9×6 by shifting 6 to the left three times and then adding 6 to that result. Show the best way to calculate $0 \times 33 \times 0 \times 55$ using shifts and adds/subtracts. Assume both inputs are 8-bit unsigned integers.
- 3.18 [20] <§3.4> Using a table similar to that shown in [Figure 3.10](#), calculate 74 divided by 21 using the hardware described in [Figure 3.8](#). You should show the contents of each register on each step. Assume both inputs are unsigned 6-bit integers.
- 3.19 [30] <§3.4> Using a table similar to that shown in [Figure 3.10](#), calculate 74 divided by 21 using the hardware described in [Figure 3.11](#). You should show the contents of each register on each step. Assume A and B are unsigned 6-bit integers. This algorithm requires a slightly different approach than that shown in [Figure 3.9](#). You will want to think hard about this, do an experiment or two, or else go to the web to figure out how to make this work correctly. (Hint: one possible solution involves using the fact that [Figure 3.11](#) implies the remainder register can be shifted either direction.)
- 3.20 [5] <§3.5> What decimal number does the bit pattern $0 \times 0c000000$ represent if it is a two's complement integer? An unsigned integer?
- 3.21 [10] <§3.5> If the bit pattern $0 \times 0c000000$ is placed into the Instruction Register, what MIPS instruction will be executed?
- 3.22 [10] <§3.5> What decimal number does the bit pattern $0 \times 0c000000$ represent if it is a floating point number? Use the

IEEE 754 standard.

- 3.23 [10] <§3.5>Write down the binary representation of the decimal number 63.25 assuming the IEEE 754 single precision format.
- 3.24 [10] <§3.5>Write down the binary representation of the decimal number 63.25 assuming the IEEE 754 double precision format.
- 3.25 [10] <§3.5>Write down the binary representation of the decimal number 63.25 assuming it was stored using the single precision IBM format (base 16, instead of base 2, with 7 bits of exponent).
- 3.26 [20] <§3.5>Write down the binary bit pattern to represent -1.5625×10^{-1} assuming a format similar to that employed by the DEC PDP-8 (the leftmost 12 bits are the exponent stored as a two's complement number, and the rightmost 24 bits are the fraction stored as a two's complement number). No hidden 1 is used. Comment on how the range and accuracy of this 36-bit pattern compares to the single and double precision IEEE 754 standards.
- 3.27 [20] <§3.5>IEEE 754-2008 contains a half precision that is only 16 bits wide. The leftmost bit is still the sign bit, the exponent is 5 bits wide and has a bias of 15, and the mantissa is 10 bits long. A hidden 1 is assumed. Write down the bit pattern to represent -1.5625×10^{-1} assuming a version of this format, which uses an excess-16 format to store the exponent. Comment on how the range and accuracy of this 16-bit floating point format compares to the single precision IEEE 754 standard.
- 3.28 [20] <§3.5>The Hewlett-Packard 2114, 2115, and 2116 used a format with the leftmost 16 bits being the fraction stored in two's complement format, followed by another 16-bit field which had the leftmost 8 bits as an extension of the fraction (making the fraction 24 bits long), and the rightmost 8 bits representing the exponent. However, in an interesting twist, the exponent was stored in sign-magnitude format with the sign bit on the far right! Write down the bit pattern to represent -1.5625×10^{-1} assuming this format. No hidden 1 is used. Comment on how the range and accuracy of this 32-bit pattern compares to the single precision IEEE 754 standard.
- 3.29 [20] <§3.5>Calculate the sum of 2.6125×10^1 and $4.150390625 \times 10^{-1}$ by hand, assuming A and B are stored in the 16-bit half precision described in [Exercise 3.27](#). Assume 1 guard, 1 round bit, and 1 sticky bit, and round to the nearest even. Show all the

steps.

- 3.30 [30] <§3.5> Calculate the product of -8.0546875×10^0 and $-1.79931640625 \times 10^{-1}$ by hand, assuming A and B are stored in the 16-bit half precision format described in [Exercise 3.27](#). Assume 1 guard, 1 round bit, and 1 sticky bit, and round to the nearest even. Show all the steps; however, as is done in the example in the text, you can do the multiplication in human-readable format instead of using the techniques described in [Exercises 3.12](#) through [3.14](#). Indicate if there is overflow or underflow. Write your answer in both the 16-bit floating point format described in [Exercise 3.27](#) and also as a decimal number. How accurate is your result? How does it compare to the number you get if you do the multiplication on a calculator?
- 3.31 [30] <§3.5> Calculate by hand 8.625×10^1 divided by -4.875×10^0 . Show all the steps necessary to achieve your answer. Assume there is a guard, a round bit, and a sticky bit, and use them if necessary. Write the final answer in both the 16-bit floating point format described in [Exercise 3.27](#) and in decimal and compare the decimal result to that which you get if you use a calculator.
- 3.32 [20] <§3.10> Calculate $(3.984375 \times 10^{-1} + 3.4375 \times 10^{-1}) + 1.771 \times 10^3$ by hand, assuming each of the values is stored in the 16-bit half precision format described in [Exercise 3.27](#) (and also described in the text). Assume 1 guard, 1 round bit, and 1 sticky bit, and round to the nearest even. Show all the steps, and write your answer in both the 16-bit floating point format and in decimal.
- 3.33 [20] <§3.10> Calculate $3.984375 \times 10^{-1} + (3.4375 \times 10^{-1} + 1.771 \times 10^3)$ by hand, assuming each of the values is stored in the 16-bit half precision format described in [Exercise 3.27](#) (and also described in the text). Assume 1 guard, 1 round bit, and 1 sticky bit, and round to the nearest even. Show all the steps, and write your answer in both the 16-bit floating point format and in decimal.
- 3.34 [10] <§3.10> Based on your answers to [Exercises 3.32](#) and [3.33](#), does $(3.984375 \times 10^{-1} + 3.4375 \times 10^{-1}) + 1.771 \times 10^3 = 3.984375 \times 10^{-1} + (3.4375 \times 10^{-1} + 1.771 \times 10^3)$?
- 3.35 [30] <§3.10> Calculate $(3.41796875 \times 10^{-3} \times 6.34765625 \times 10^{-3}) \times 1.05625 \times 10^2$ by hand, assuming each of the values is stored in the 16-bit half precision format described in [Exercise 3.27](#) (and also described in the text). Assume 1 guard, 1 round bit, and 1 sticky bit, and round to the nearest even. Show all the steps, and

write your answer in both the 16-bit floating point format and in decimal.

- 3.36 [30] <§3.10> Calculate $3.41796875 \times 10^{-3} \times (6.34765625 \times 10^{-3} \times 1.05625 \times 10^2)$ by hand, assuming each of the values is stored in the 16-bit half precision format described in [Exercise 3.27](#) (and also described in the text). Assume 1 guard, 1 round bit, and 1 sticky bit, and round to the nearest even. Show all the steps, and write your answer in both the 16-bit floating point format and in decimal.
- 3.37 [10] <§3.10> Based on your answers to [Exercises 3.35](#) and [3.36](#), does $(3.41796875 \times 10^{-3} \times 6.34765625 \times 10^{-3}) \times 1.05625 \times 10^2 = 3.41796875 \times 10^{-3} \times (6.34765625 \times 10^{-3} \times 1.05625 \times 10^2)$?
- 3.38 [30] <§3.10> Calculate $1.666015625 \times 10^0 \times (1.9760 \times 10^4 + -1.9744 \times 10^4)$ by hand, assuming each of the values is stored in the 16-bit half precision format described in [Exercise 3.27](#) (and also described in the text). Assume 1 guard, 1 round bit, and 1 sticky bit, and round to the nearest even. Show all the steps, and write your answer in both the 16-bit floating point format and in decimal.
- 3.39 [30] <§3.10> Calculate $(1.666015625 \times 10^0 \times 1.9760 \times 10^4) + (1.666015625 \times 10^0 \times -1.9744 \times 10^4)$ by hand, assuming each of the values is stored in the 16-bit half precision format described in [Exercise 3.27](#) (and also described in the text). Assume 1 guard, 1 round bit, and 1 sticky bit, and round to the nearest even. Show all the steps, and write your answer in both the 16-bit floating point format and in decimal.
- 3.40 [10] <§3.10> Based on your answers to [Exercises 3.38](#) and [3.39](#), does $(1.666015625 \times 10^0 \times 1.9760 \times 10^4) + (1.666015625 \times 10^0 \times -1.9744 \times 10^4) = 1.666015625 \times 10^0 \times (1.9760 \times 10^4 + -1.9744 \times 10^4)$?
- 3.41 [10] <§3.5> Using the IEEE 754 floating point format, write down the bit pattern that would represent $-1/4$. Can you represent $-1/4$ exactly?
- 3.42 [10] <§3.5> What do you get if you add $-1/4$ to itself four times? What is $-1/4 \times 4$? Are they the same? What should they be?
- 3.43 [10] <§3.5> Write down the bit pattern in the fraction of value $1/3$ assuming a floating point format that uses binary numbers in the fraction. Assume there are 24 bits, and you do not need to normalize. Is this representation exact?
- 3.44 [10] <§3.5> Write down the bit pattern in the fraction of value

1/3 assuming a floating point format that uses Binary Coded Decimal (base 10) numbers in the fraction instead of base 2. Assume there are 24 bits, and you do not need to normalize. Is this representation exact?

3.45 [10] <§3.5>Write down the bit pattern assuming that we are using base 15 numbers in the fraction of value 1/3 instead of base 2. (Base 16 numbers use the symbols 0–9 and A–F. Base 15 numbers would use 0–9 and A–E.) Assume there are 24 bits, and you do not need to normalize. Is this representation exact?

3.46 [20] <§3.5>Write down the bit pattern assuming that we are using base 30 numbers in the fraction of value 1/3 instead of base 2. (Base 16 numbers use the symbols 0–9 and A–F. Base 30 numbers would use 0–9 and A–T.) Assume there are 20 bits, and you do not need to normalize. Is this representation exact?

3.47 [45] <§§3.6, 3.7>The following C code implements a four-tap FIR filter on input array `sig_in`. Assume that all arrays are 16-bit fixed-point values.

```
for (i = 3; i < 128; i++)
    sig_out[i] = sig_in[i - 3] * f[0] + sig_in[i - 2] * f[1]
    + sig_in[i - 1] * f[2] + sig_in[i] * f[3];
```

Assume you are to write an optimized implementation of this code in assembly language on a processor that has SIMD instructions and 128-bit registers. Without knowing the details of the instruction set, briefly describe how you would implement this code, maximizing the use of sub-word operations and minimizing the amount of data that is transferred between registers and memory. State all your assumptions about the instructions you use.

Answers to Check Yourself

§3.2, page 177: 2.

§3.5, page 215: 3.